

Note!

Before installing this product, check the contents of the kit. If anything is missing, please check an Öhlins dealer.

Kit Contents

Description	Part No	Pcs
Shock absorber	DU 626	1
Bracket Reservoir 44	03102-15	1
Screw M6x14	00382-16	1
Bracket Reservoir	60006-16	1
Screw M6x12	00432-11	2
C-spanner	00710-02	1
Sticker "Memo notes"	01180-01	1
Sticker set R&T "ÖHLINS"	10207-01	1
Owners manual road & track	07241-02	1

Note!

Please note that this image is a general representation of the product and may differ slightly from your product.

Note!

Please note that during storage and transportation, especially at high ambient temperature, some of the oil and grease used for assembling may leak and stain the packaging. This is in no way detrimental to the product, wipe off the excessive oil/grease with a cloth.

Warning!

Before installing this product, read the Öhlins Owner's Manual. The shock absorber is an important part of your vehicle and will affect the stability.

Shock Absorber for Ducati X-Diavel Blackline

DU 626

Mounting Instructions

MOUNTING INSTRUCTIONS

⚠ Warning!

It is advisable to have an Öhlins dealer install the shock absorber.

⚠ Warning!

If working on a raised vehicle, ensure it is securely supported so that it will not tip over.

👁 Note!

Before mounting this product clean the vehicle thoroughly.

👁 Note!

When working on this product, always see the Vehicle Service Manual for vehicle specific procedures and important data.

1.

Put the motorcycle on the work stand so that the rear wheel barely touches the ground. Make sure the motorcycle is in a stable position.

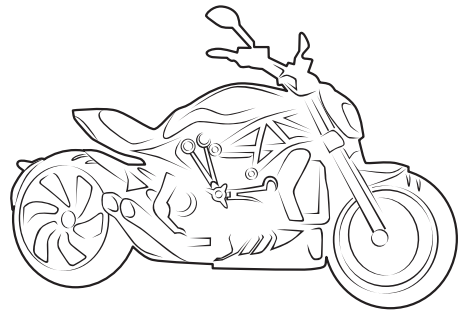

2.

Remove the rear hugger **(A)** by loosening the screws **(1)** **(2)** and **(3)** **(4)** (**(3)** **(4)** are located on the opposite side).

3.

Remove the drive belt cover **(B)** by loosening the screws **(5)** **(6)** **(7)**.

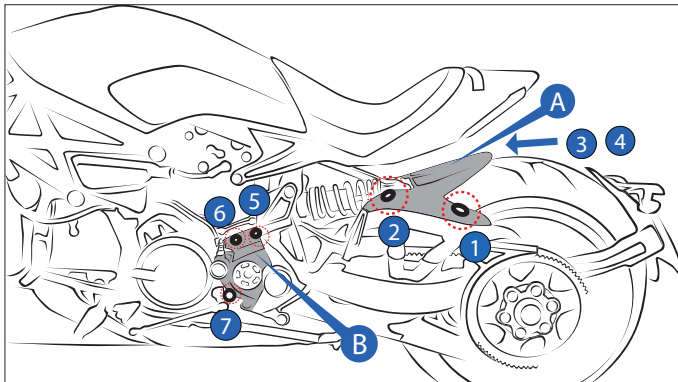

MOUNTING INSTRUCTIONS

4.

Remove the left side foot peg by loosening the screw ①②③.

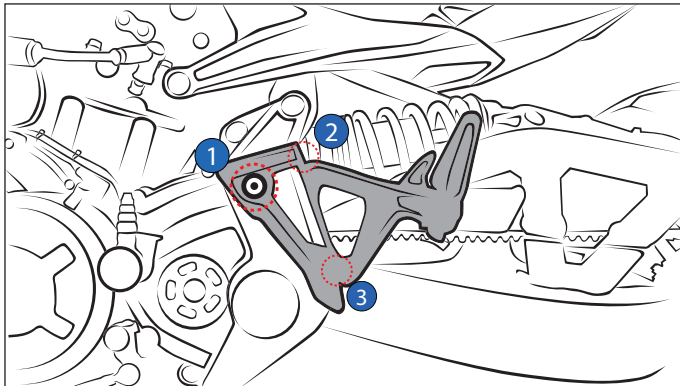

5.

Remove the left side plate by loosening the screws ①②③④⑤⑥.

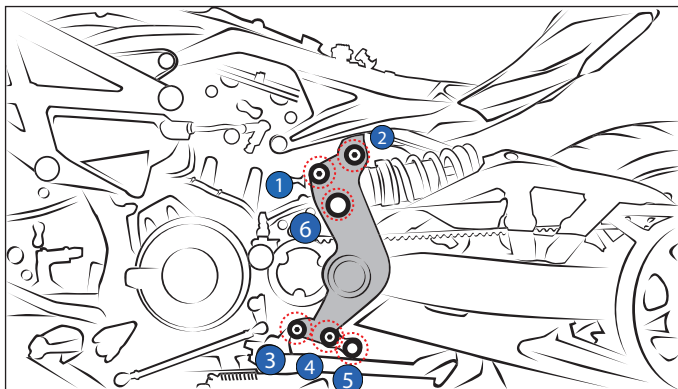

MOUNTING INSTRUCTIONS

6.

Release the standard reservoir (E) by loosening the screw (1). Remove the standard reservoir bracket by loosening the screws (2)(3).

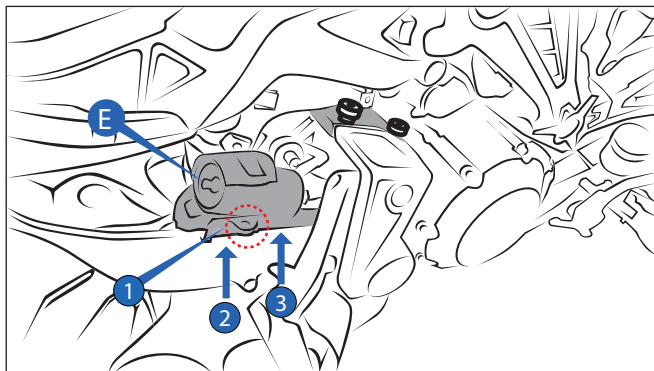

7.

Remove the heat shield (C) by loosening the screws (1)(2)(3).

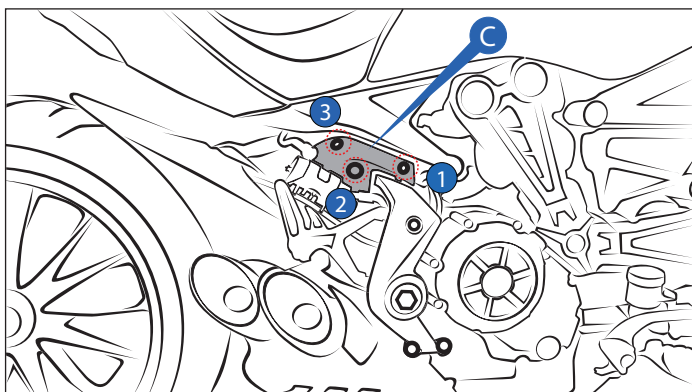

MOUNTING INSTRUCTIONS

8.

Remove the foot peg (B) by loosen the two screws ⑤ ⑥. Remove the black bracket for exhaust pipe and heat shield, två M6, 5 mm hex. Remove the other screws ① ② ③ ④ and pull out the side plate as much as possible to access to two 7 mm hex on top of the side plate. Loosen the 7 mm hex and remove the side plate A and the aluminum bridge on which the black bracket is mounted.

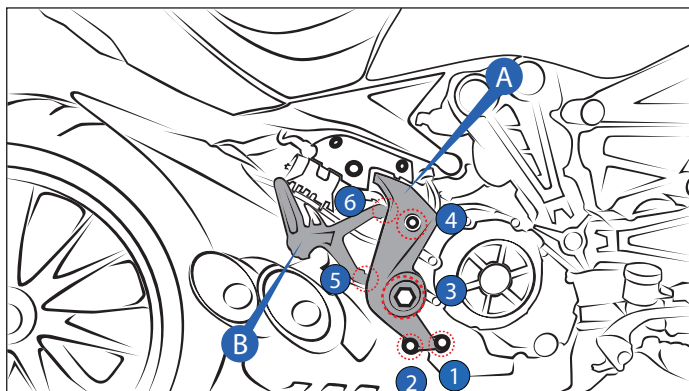

9.

Uninstall the standard shock absorber by loosening the upper and lower mounting screws ① ②.

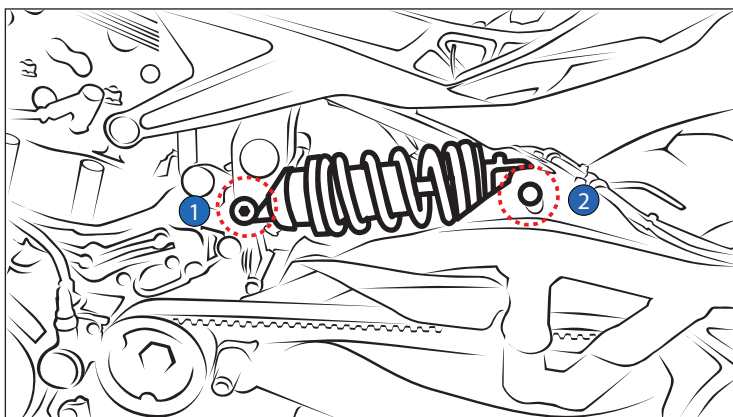

MOUNTING INSTRUCTIONS

10.

Install the Öhlins shock absorber as per installation diagram. Tighten at a torque value as specified in the vehicle service manual.

Reverse all procedures as necessary.

Mount the bracket centered on the thick part of the gas reservoir. Adjust the reservoir about 40 degrees vs horizontal plane according to the picture:

Note!

Lower the vehicle so that the suspension is slightly compressed before tightening the screws.

Caution!

Ensure that all screws are tightened to the correct torque and that nothing fouls or restricts movement of the shock absorber when the suspension is fully compressed or extended.

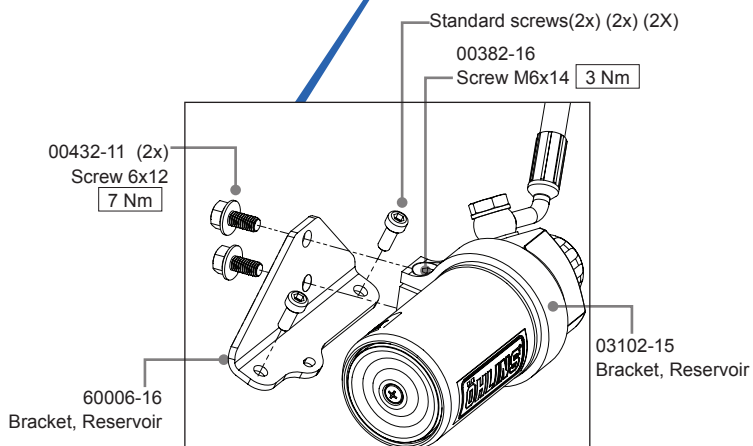
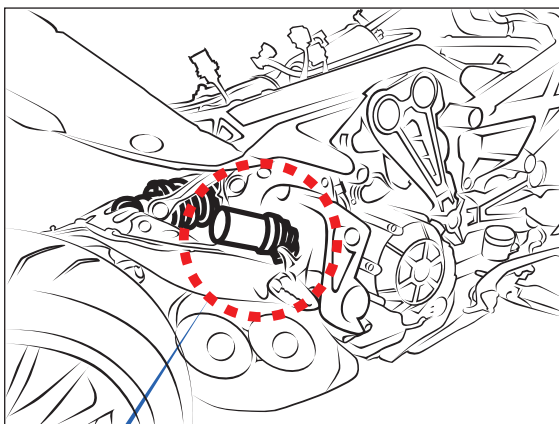
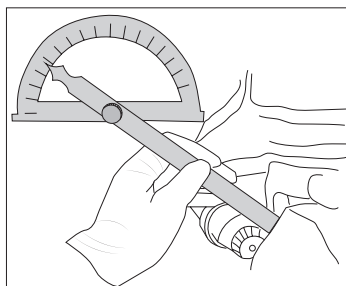

This page intentionally left blank

ADJUSTMENTS

⚠ Warning!

Before riding, always make sure that the basic settings made by Öhlins are according to recommended Set-up Data. Read about adjustments and setting up in the Öhlins Owner's Manual before you make any adjustments. Contact an Öhlins dealer if you have any questions about setting up.

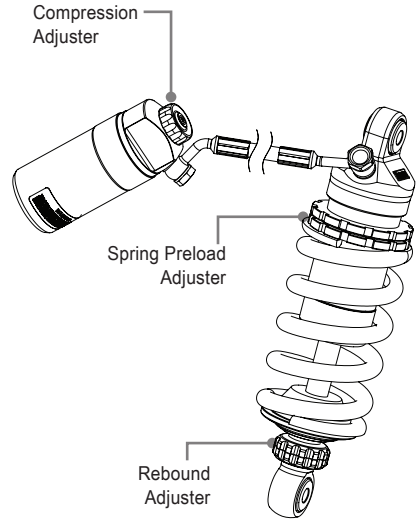

SET-UP DATA

Recommended set-up

Spring Preload.....	14 mm.
Compression adjuster	12 Clicks
Rebound adjuster	14 Clicks

Shock absorber data

Length	265 mm.
Stroke	61 mm.

Spring

Part No	21115-24
Free spring length	150 mm.
Spring rate	80 N/mm
Preload adj.range	[0-19] mm

👁 Öhlins products are subject to continuous improvement and development, therefore, although these instructions include the most up-to-date information available at the time of printing, minor updates may occur.

To find the latest information contact an Öhlins distributor. Please contact Öhlins if you have any questions regarding the contents in this document.

Part no. MI_DU 626_EN_1
Issued 2020-12-04

© Öhlins Asia Co. Ltd. All rights reserved. Any reprinting or unauthorized use without the written permission of Öhlins Racing AB is prohibited.

Öhlins Asia Co. Ltd
700/937 Moo5, Tambol Nongkhaga,
Amphur Phantong, Chonburi Province
20160 Thailand



www.ohlins.com