

### **Note!**

Before installing this product, check the contents of the kit. If anything is missing, please check an Öhlins dealer.

### **Kit Contents**

Description	Part No	Pcs
Shock absorber	DU 726	1
Bracket Reservoir 44	03102-15	1
Screw M6x14	00382-16	1
Bracket Reservoir	60006-16	1
Screw M6x12	00432-11	2
C-spanner S46	60710-02	1
Sticker set R&T "ÖHLINS"	10207-01	1
Owners manual road & track	07241-02	1

### **Note!**

Please note that this image is a general representation of the product and may differ slightly from your product.

### **Note!**

Please note that during storage and transportation, especially at high ambient temperature, some of the oil and grease used for assembling may leak and stain the packaging. This is in no way detrimental to the product, wipe off the excessive oil/grease with a cloth.

### **Warning!**

Before installing this product, read the Öhlins Owner's Manual. The shock absorber is an important part of your vehicle and will affect the stability.

## Shock Absorber for Ducati X-Diavel

# **DU 726**

## Mounting Instructions

# MOUNTING INSTRUCTIONS

## **⚠ Warning!**

*It is advisable to have an Öhlins dealer install the shock absorber.*

## **⚠ Warning!**

*If working on a raised vehicle, ensure it is securely supported so that it will not tip over.*

## **👁 Note!**

*Before mounting this product clean the vehicle thoroughly.*

## **👁 Note!**

*When working on this product, always see the Vehicle Service Manual for vehicle specific procedures and important data.*

1.  
Put the motorcycle on the work stand so that the rear wheel barely touches the ground. Make sure the motorcycle is in a stable position.

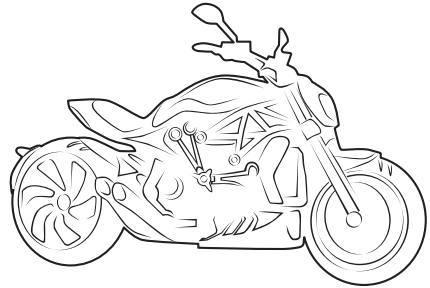

2.  
Remove the rear hugger (A) by loosening the screws ① ② and ③ ④ (③ ④ are located on the opposite side)

3.  
Remove the drive belt cover (B) by loosening the screws ⑤ ⑥ ⑦

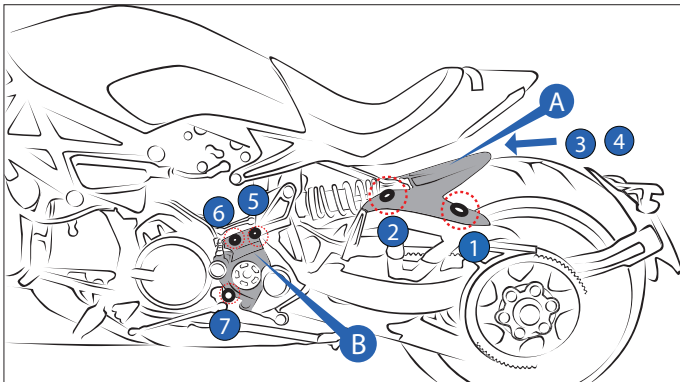

# MOUNTING INSTRUCTIONS

4

Remove the left side foot peg by loosening the screw ①

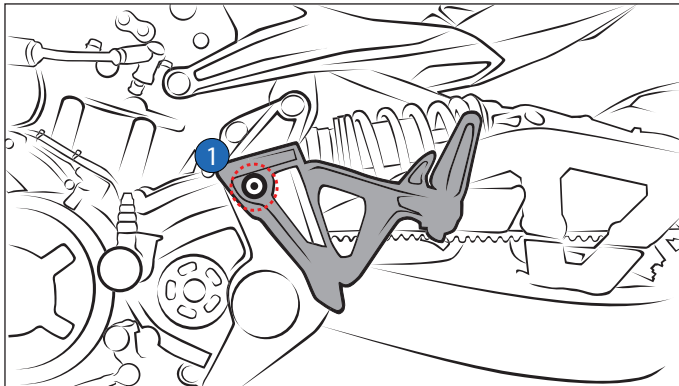

5

Remove the left side plate by loosening the screws ① ② ③ ④ ⑤

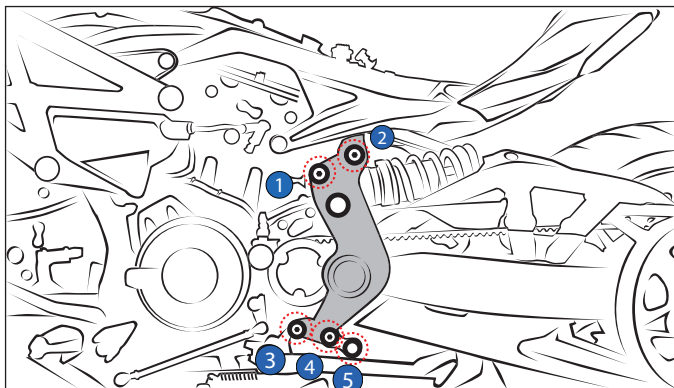

# MOUNTING INSTRUCTIONS

6.

Remove the right side plate **A** and the foot peg **B** by loosening the screws **1 2 3 4**

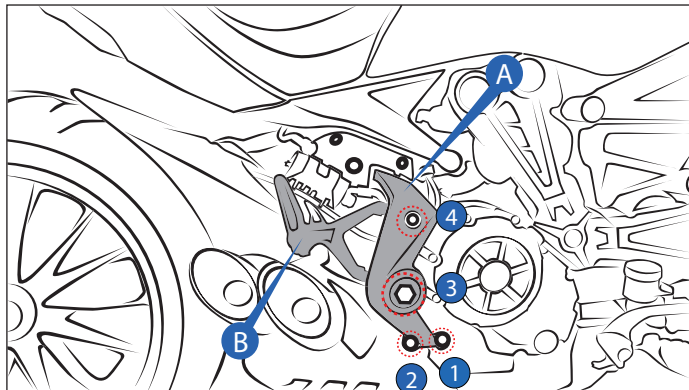

7.

Remove the heat shield **C** by loosening the screws **1 2 3**

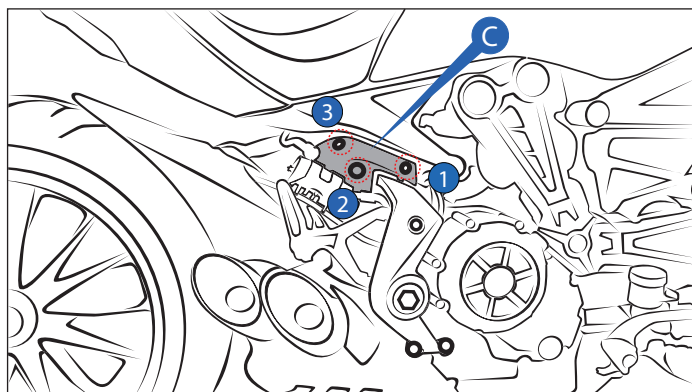

# MOUNTING INSTRUCTIONS

8.

Remove the plate **D** by loosening the screws **1** **2** for ease to move the reservoir **E**

9.

Release the standard reservoir **E** by loosening the screw **3**

10.

Remove the standard reservoir bracket by loosening the screws **4** **5**

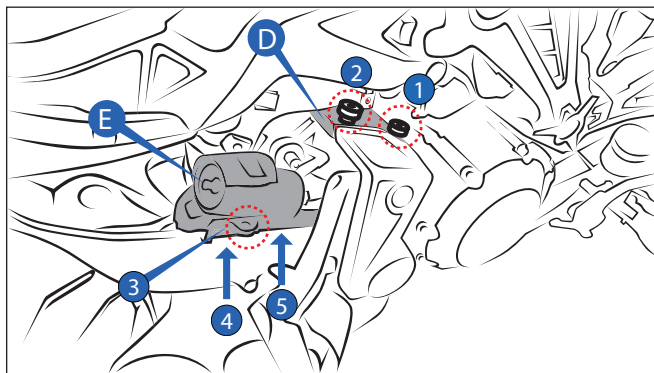

11.

Uninstall the standard shock absorber by loosening the upper and lower mounting screws **1** **2**

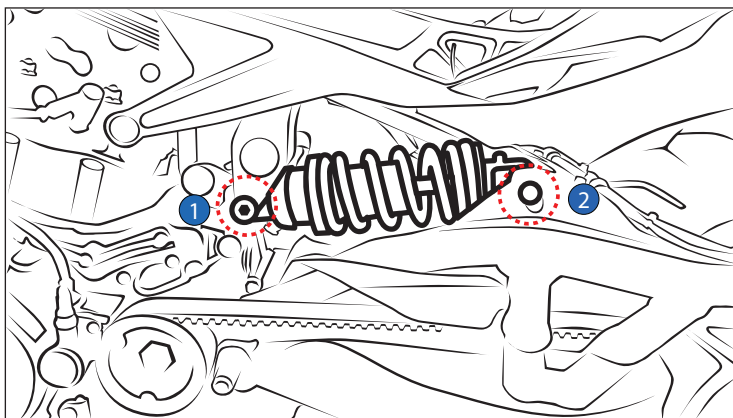

# MOUNTING INSTRUCTIONS

12.

Install the Öhlins shock absorber as per installation diagram. Tighten at a torque value as specified in the vehicle service manual.

Reverse all procedures as necessary.

## **Note!**

*Lower the vehicle so that the suspension is slightly compressed before tightening the screws.*

## **Caution!**

*Ensure that all screws are tightened to the correct torque and that nothing fouls or restricts movement of the shock absorber when the suspension is fully compressed or extended.*

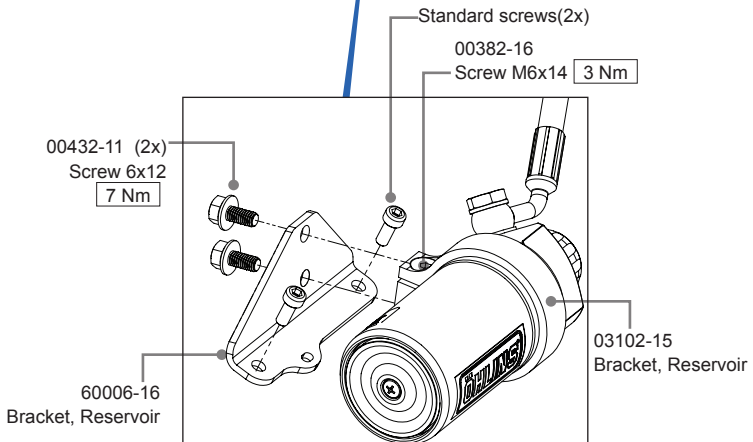
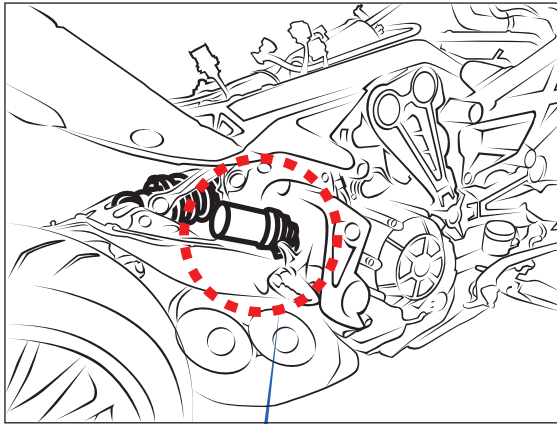

This page intentionally left blank

# ADJUSTMENTS

## ⚠ Warning!

Before riding, always make sure that the basic settings made by Öhlins are according to recommended Set-up Data. Read about adjustments and setting up in the Öhlins Owner's Manual before you make any adjustments. Contact an Öhlins dealer if you have any questions about setting up.

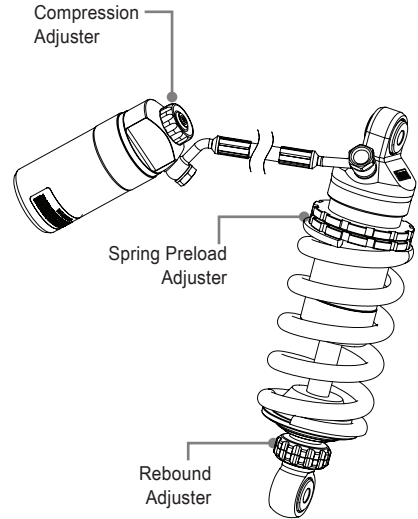

# SET-UP DATA

## Recommended set-up

Spring Preload.....	14 mm.
Compression adjuster .....	12 Clicks
Rebound adjuster .....	14 Clicks

## Shock absorber data

Length .....	265 mm.
Stroke .....	61 mm.

## Spring

Part No	21115-24
Free spring length	150 mm.
Spring rate	80 N/mm
Preload adj.range	[0-19] mm

👁 Öhlins products are subject to continuous improvement and development, therefore, although these instructions include the most up-to-date information available at the time of printing, minor updates may occur.

To find the latest information contact an Öhlins distributor. Please contact Öhlins if you have any questions regarding the contents in this document.

Part no. MI\_DU 726\_EN\_0  
Issued 2017-11-10

© Öhlins Asia Co. Ltd. All rights reserved. Any reprinting or unauthorized use without the written permission of Öhlins Racing AB is prohibited.

Öhlins Asia Co. Ltd  
700/937 Moo5, Tambol Nongkhaga,  
Amphur Phantong, Chonburi Province  
20160 Thailand



[www.ohlins.com](http://www.ohlins.com)