

**⚠ Warning!**

Only approved Öhlins personnel are permitted to install this kit. The procedure requires specific tools. Before you install this product, read the Öhlins Owner's manual. This product is an important part of the vehicle and the vehicle stability.

**👁 Note!**

Before you install this product, check the kit contents. If anything is missing, please contact an Öhlins dealer.

Kit Contents		
Description	Part No	Pcs
Front fork kit	FGK217	1
Sticker set Öhlins		1
Owner's manual	07284-01	1
Plug	21652-02	2

Recommended tools	
Fork tube tool Ø41	00786-08
Top cap tool	00797-08
Pull up tool	01765-03
Seal head tool	01797-07

Oil, grease and threadlocker	
Function grease CaH92	00159-01
Öhlins front fork fluid	01309-xx
Threadlocker, high, Loctite 2701	01791-05
Threadlocker, medium, Loctite 243	01791-03

**👁 Note!**

Please note that during storage and transport, especially at high ambient temperature, some of the oil and grease used for assembly may leak and stain the packaging. This will not cause damage to the product, wipe off the excessive oil or grease with a cloth.

**👁 Note!**

Please note that there can be small differences between your product and the images in these instructions.

## Front Fork Kit for Suzuki GSX-R600/750

# FGK 217

## Mounting Instructions



# MOUNTING INSTRUCTIONS

## **⚠ Warning!**

We strongly recommend to let an Öhlins dealer install this product.

## **⚠ Warning!**

If you work with a lifted vehicle, make sure that it is safely supported to prevent it from tipping over.

## **👁 Note!**

When you work with this product, see the vehicle service manual for vehicle specific procedures and important data.

## **👁 Note!**

Before you install this product clean the vehicle.

## **1 Remove the original front fork**

### **1.1**

Put the motorcycle on a work stand so that the front wheel barely touches the ground.

### **1.2**

Remove the front fender, the brake calipers and the front wheel.

### **1.3**

Release the spring preload.

### **1.4**

Note the fork leg position.

### **1.5**

Loosen the screws to loosen the upper triple clamp.

### **1.6**

See the vehicle service manual for correct tool to loosen the top cap 1/2 turn, do not remove it.

### **1.7**

Loosen the screws to loosen the lower triple clamp.

### **1.8**

Remove the fork legs.

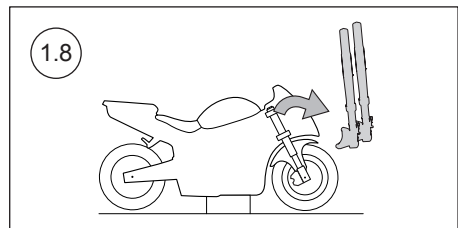
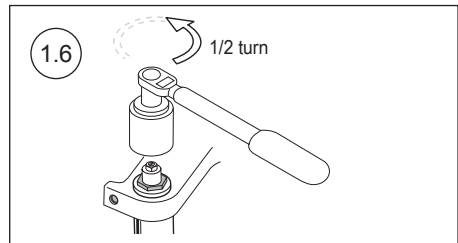
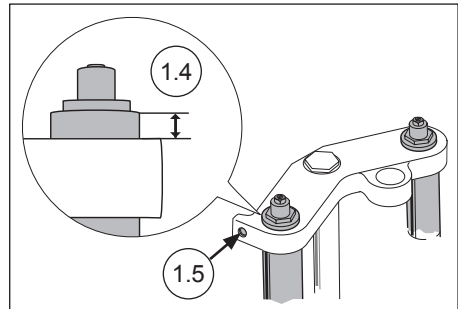
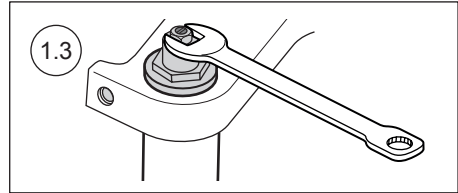
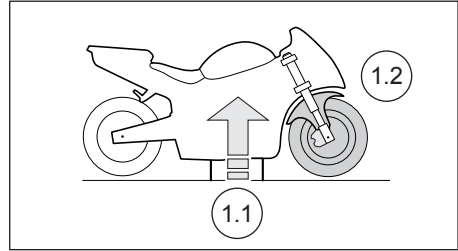

# MOUNTING INSTRUCTIONS

## 2 Disassemble the original front fork

### 2.1

Loosen the top cap from the outer tube. Pull down the outer tube.

### 2.2

See the vehicle service manual for correct tools to do these steps:

- remove the top cap
- loosen the seal head from the steel tube
- remove the original cartridge

### 2.3

Remove the upper spring collar and the spring.

### 2.4

Drain the fork leg from oil and remove the lower spring collar. Note that the spring collar can have a different size or shape than the one in the image.

### 2.5

Push the outer tube as far up as possible. Install the fork tube tool (00786-0X) on the steel tube, close to the outer tube.

### ⚠ Caution!

*It is important to remove the lock screw in step 2.6 to prevent damage to the steel tube.*

### 2.6

Apply heat with a heat gun to break down the threadlocker between the steel tube lock screw and the fork bottom. See the vehicle service manual for correct tool to remove the steel tube lock screw.

### 2.7

Apply heat with a heat gun to break down the threadlocker between the steel tube and the fork bottom. Use the fork tube tool to loosen and remove the steel tube from the fork bottom.

### 👁 Note!

*Do not remove the fork tube tool from the steel tube yet. You will need it to install the steel tube.*

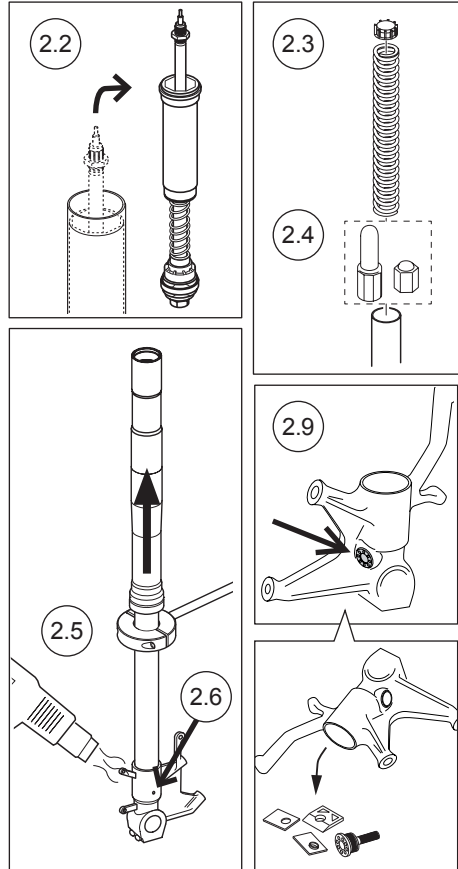

### 2.8

Remove the O-ring and the steel washer from the fork bottom. Note that you will not need the steel washer for the Öhlins kit.

Clean the threads in the fork bottom and on the inner tube, make sure that there is no threadlocker left.

### 2.9

See the vehicle service manual for correct tool to loosen the spring preload adjuster on the fork bottom. Remove the spring preload adjuster parts.

# MOUNTING INSTRUCTIONS

## 3 Install the Öhlins front fork kit

### ⚠ Caution!

We strongly recommend that you work with one leg at a time, make sure not to mix the parts.

### ⚠ Caution!

The kit consists of one compression cartridge and one rebound cartridge. Note the marks. Make sure that you install the cartridge in the correct fork leg; REB (Rebound) in the right fork leg. COMP (Compression) in the left fork leg.

#### 3.1

Remove the top cap.

#### 3.2

Remove the spring support and the preload tube.

#### 3.3

Remove the cylinder tube from the cartridge.

### ⚠ Caution!

Be careful not to damage the piston ring.

#### 3.4

Remove the steel adaptor from the cylinder tube adaptor.

#### 3.5

Insert the steel adaptor in the fork bottom.

### 👁 Note!

Make sure to install the adaptor correctly. See figure.

#### 3.6

Apply function grease (00159-01) on the original O-ring and insert it in the fork bottom.

### 👁 Note!

Do not install the original steel washer removed in chapter 2.

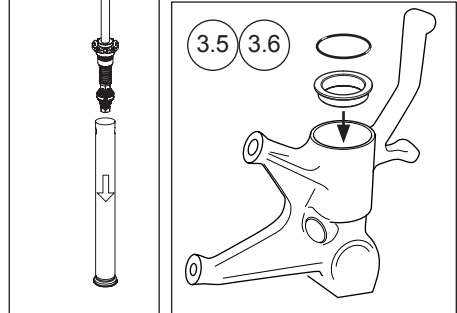
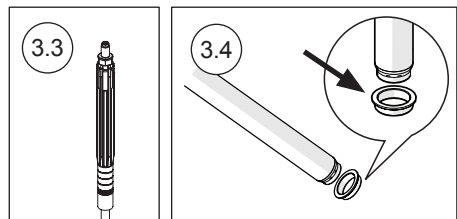
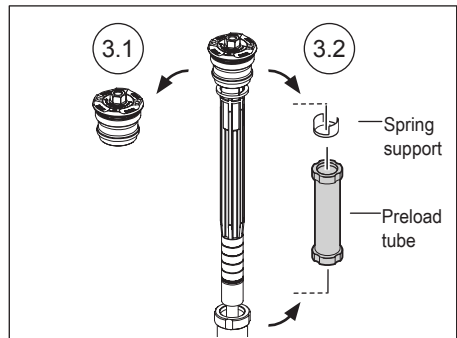

# MOUNTING INSTRUCTIONS

## 3.7

Apply function grease (00159-01) on the O-ring and install the plug provided in the kit. Tighten to 12 Nm.

## 3.8

Apply threadlocker (01791-05) on the steel tube. Tighten to 130 Nm.

## 3.9

Apply threadlocker (01791-05) on the steel tube lock screw. Tighten to 3 Nm.

## 3.10

Put the cylinder tube carefully into the fork leg. Apply threadlocker (01791-03) on the adaptor thread. Use an extended 17 mm Allen key to tighten the cylinder tube adaptor to the steel adaptor. Tighten to 40 Nm.

### **⚠ Caution!**

*Be careful not to damage the inside of the cylinder tube when you tighten with the extended allen key.*

## 3.11

Pour 0,5 litre Öhlins Front Fork fluid (01309-xx) in the fork leg.

## 3.12

Apply function grease (00159-01) on the seal head thread. Put the cartridge carefully in the fork leg. Use the seal head tool (01797-07) and tighten the cartridge to the cylinder tube to 20 Nm.

### **⚠ Caution!**

*Make sure that the piston ring is in its correct position and be careful not to damage it.*

## 3.13

Open the compression and the rebound adjusters fully. Install the top cap directly on the shaft extension, no spring or preload tube. Pull up the outer tube and tighten it to the top cap with your hands.

## 3.14

Pull the outer tube up and down 10-15 times to pump out all air from the cartridge.

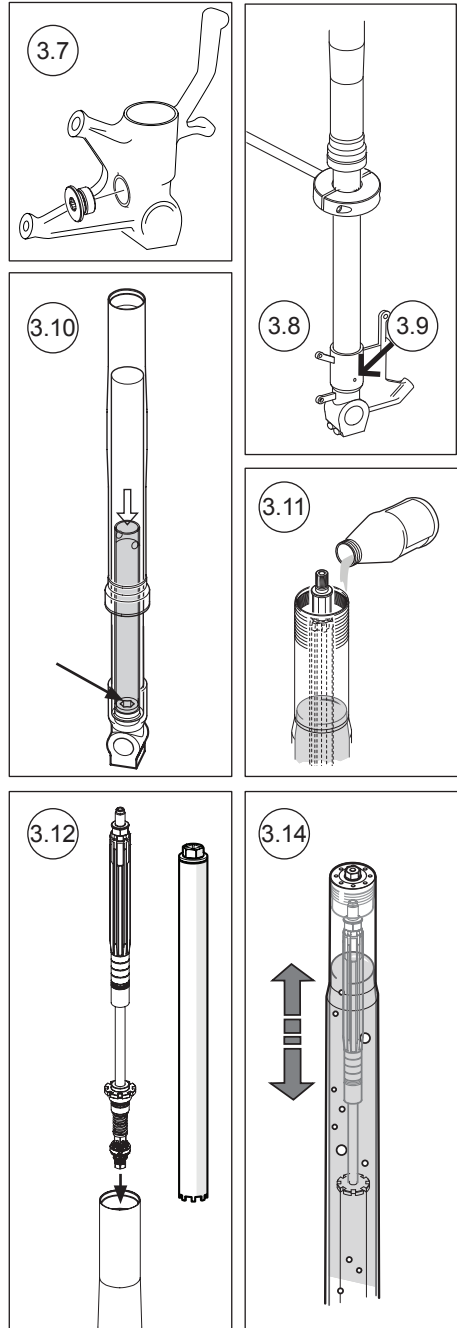

# MOUNTING INSTRUCTIONS

## 3.15

Remove the top cap from the fork leg.

## 3.16

Make sure the shaft assembly is in the bottom of the fork leg and that the outer tube is in its bottom position. Measure the oil level with a ruler. See setup data and the oil level-force diagram in this folder for recommended oil level.

## 3.17

Fasten the pull up tool (01765-03) on the shaft extender. Lead the preload tube, spring and upper spring support over the tool tool. See the Owner's Manual for available springs.

## 3.18

Pull up the shaft assembly and use a 19 mm wrench to grab the spring support.

## 3.19

Make sure that the comp/rebound adjusters are fully open before you install the top cap. Remove the pull-up tool and install the top cap to the shaft extender. Tighten to 15 Nm.

## 3.20

Pull up the outer tube. Make sure the fork leg is in a fully extended position. Use the top cap tool (00797-08) to tighten the top cap to the outer tube, tighten to 10 Nm.

## 3.21

Set the spring preload, rebound and compression adjusters according to the setup data in this this folder.

## 3.22

Install the front fork legs into the triple clamps at the fork leg position recommended in the setup data. Tighten according to the vehicle service manual.

### **Note!**

Measure the fork leg extension from the upper triple clamp to the top of the outer tube.

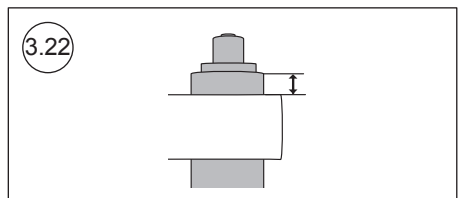
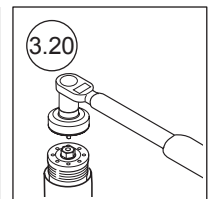
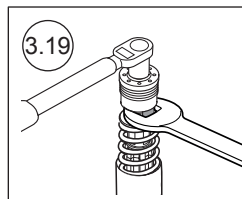
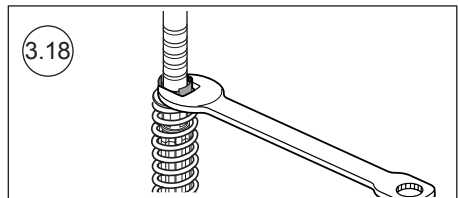
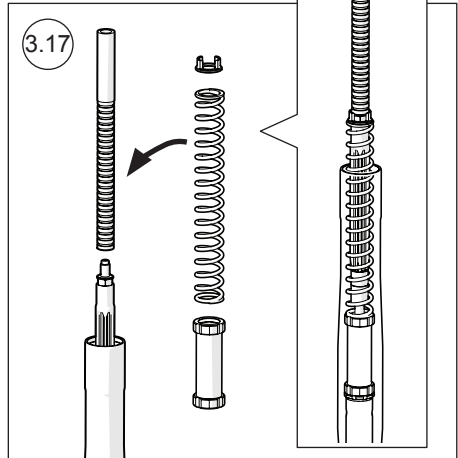
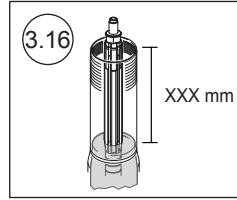

# MOUNTING INSTRUCTIONS

This page intentionally left blank.

# SETUP DATA

Compression	12	clicks
Rebound	12	clicks
Spring rate	9.5	N/mm
Spring preload	5	mm
Oil level	170	mm
Fork leg position	0	mm

## Oil level - Air spring force Diagram

Air spring for one front fork leg

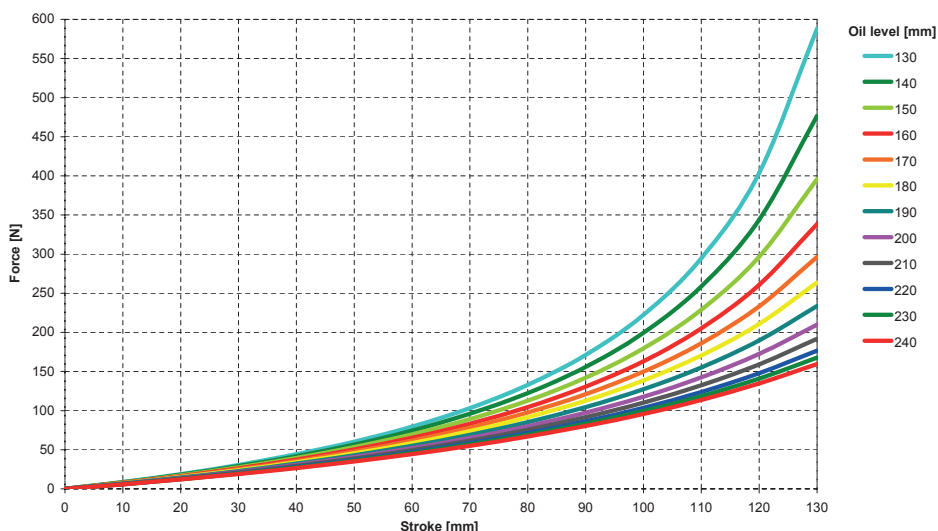

Öhlins products are subject to continuous improvement and development, therefore, although these instructions include the most up-to-date information available at the time of printing, minor updates may occur.

To find the latest information contact an Öhlins distributor. Please contact Öhlins if you have any questions regarding the contents in this document.

Part no. MI\_FGK217\_2  
Issued 2017-01-01

© Öhlins Racing AB. All rights reserved. Any reprinting or unauthorized use without the written permission of Öhlins Racing AB is prohibited.

Öhlins Racing AB  
Box 722  
S-194 27 Upplands Väsby, Sweden  
Phone +46 8 590 025 00  
fax +46 8 590 025 80



[www.ohlins.com](http://www.ohlins.com)