

Before installing this product, check the contents of the kit. If anything is missing, please contact your nearest Öhlins dealer.

Kit Contents

	Part No.	Pcs.
Front fork	FGRT204	1
Sleeve	04785-08	4
Sticker set Öhlins		1
Owner's manual	07282-07	1

Please note that during storage and transportation, especially at high ambient temperature, some of the oil and grease used for assembling may leak and stain the packaging. This is in no way detrimental to the product, wipe off the excessive oil/grease with a cloth.

⚠ Warning!

Before installing this product, read the Öhlins Owner's Manual. The front fork is an important part of your vehicle and will affect the stability.

Front Fork for Honda CBR 1000RR / ABS

FGRT 204

Mounting Instructions



How to Install

⚠ Warning!

It is advisable to have an Öhlins dealer install the front fork.

⚠ Warning!

When installing, read the Vehicle Service Manual.

⚠ Warning!

Make sure the vehicle is securely supported so that it will not tip.

1

Put the motorcycle on a workstand so that the front wheel is off the ground.

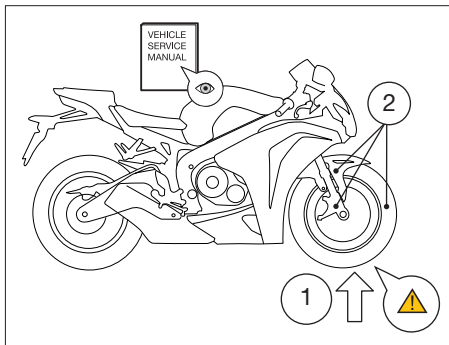

2

Remove the front fender, brake caliper, ABS-sensor (if any) and the front wheel.

3

Measure the distance from the top of the outer fork leg to the top of the upper triple clamp. Normal position is 0 mm.

👁 Note!

It is very important that the front fork is reattached at the exact same position.

4

Loosen the upper and lower triple clamps by loosening the screws.

5

Remove the fork legs from the triple clamps.

⚠ Warning!

The surface of the outer machining must be 90° from the vehicle direction.

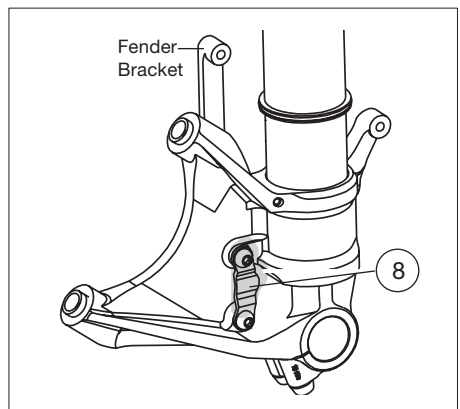
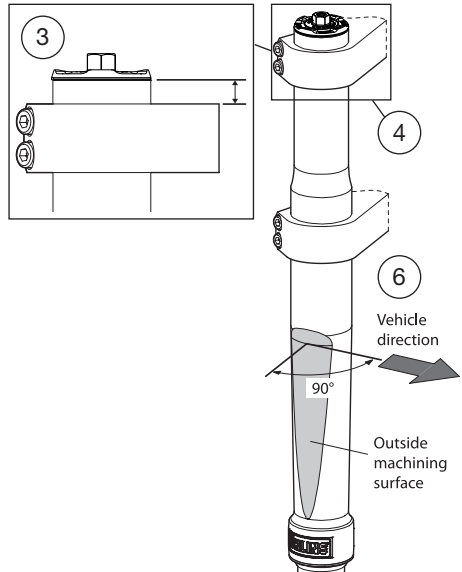

6

Install the fork legs into the triple clamps at the same height as measured in figure 3. Turn the handle bars fully from side to side to make sure that nothing restricts the movement, and that the throttle cable and wire harness runs in smooth bends.

7

Tighten the triple clamps with the following torque: Upper fork crown 20 Nm and lower fork crown 10 Nm.

8

Vehicle equipped with ABS; Remove the cover plate from the right hand side fork bottom and reinstall the ABS-sensor.

9

Reinstall the front fender, front wheel and the brake calipers. **Do not tighten yet.**

10

Put the bike on the ground, apply the front brake and compress the front fork distinctly 3-4 times. This will put the legs in an exact parallel position.

11

Tighten the front wheel, brake calipers and the front fender. See your vehicle service manual for the correct tightening torques.

12

Make sure nothing restricts the fork movement when fully compressed.

 **Note!**

In storage or transport the oil in the front fork can be displaced and therefore temporarily loses some of its damping performance.

13

Close the rebound and compression adjusters.

14

Repeatedly compress the front fork as much as possible to bleed the air out. Ensure there is damping on the full stroke.

15

Set the rebound and compression adjusters according to recommended set-up.

16

Read more in Öhlins Owners manual - Chapter Setting up your front fork, Extended stroke.

Adjustments

Warning!

Before riding, always make sure that the basic settings made by Öhlins are according to recommended Set-up Data. Read about adjustments and setting up in the Öhlins Owner's Manual before you make any adjustments. Contact an Öhlins dealer if you have any questions about setting up the front fork.

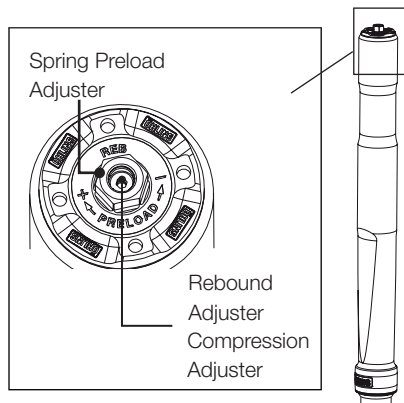

Set-up Data

Rebound adjustment	12 clicks
Compression adjustment	12 clicks
Spring preload	8 mm
Oil level	180 mm
Öhlins oil	01309
Fork leg position	0 mm

Springs

04744-95 (optional)	9,5 N/mm
04744-90 (optional)	9,0 N/mm
04744-10 (standard)	10 N/mm
04744-05 (optional)	10,5 N/mm
04744-11 (optional)	11 N/mm

Recommended Sag and Ride Height

The measures should not differ from the following recommendations:

R1 - R2	10 - 20 mm (R1-R2)
F1 - F2	20 - 30 mm (F1-F2)
R1 - R3	25 - 40 mm (R1-R3)
F1 - F3	35 - 50 mm (F1-F3)

👁️ *Read more about sag and ride height in the Öhlins Owner's Manual.*

Diagram: Oil Level - Force

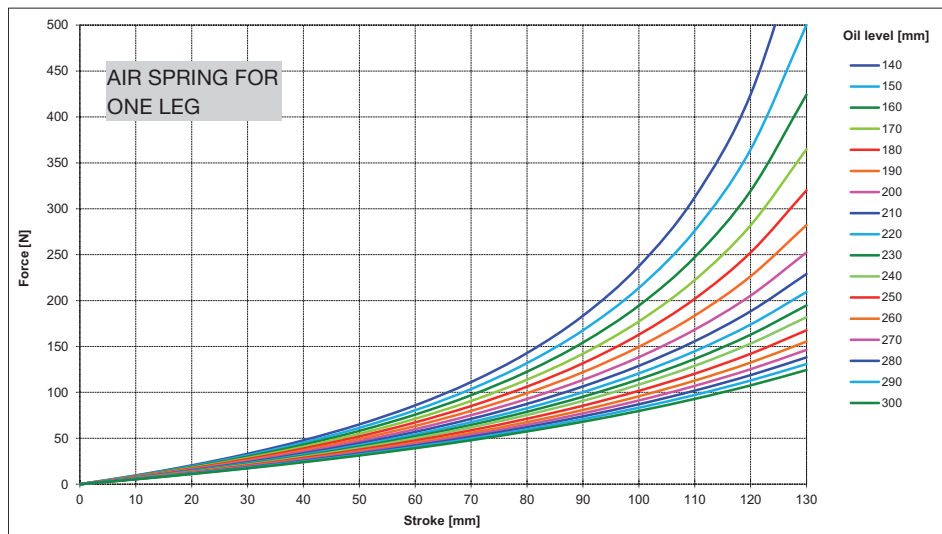

👁️ Öhlins products are subject to continuous improvement and development, therefore, although these instructions include the most up-to-date information available at the time of printing, minor updates may occur.

To find the latest information contact your Öhlins distributor. Please consult your Öhlins dealer if you have any questions regarding the contents in this document.



Part no. FGRT204_1
Issued 2017-01-01

© Öhlins Racing AB. All rights reserved. Any reprinting or unauthorized use without the written permission of Öhlins Racing AB is prohibited.

Öhlins Racing AB
Box 722
S-194 27 Upplands Väsby, Sweden
Phone +46 8 590 025 00
fax +46 8 590 025 80



www.ohlins.com