

Note!

Please note that there can be small differences between your product and the images in these instructions.

Note!

Please note that during storage and transport, especially at high ambient temperature, some of the oil and grease used for assembly may leak and stain the packaging. This will not cause damage to the product, wipe off the excessive oil or grease with a cloth.

Kit Contents

Description	Part No	Pcs
Front fork	FGRT219	1
Screw MC6S M5x10	01046-38	8
Fender bracket front	21665-09	2
Fender bracket rear	21665-17	2
Tie rap	00231-01	2
Sticker set Öhlins		1
Owner's Manual	07282-07	1

Note!

Before you install this product, check the kit contents. If anything is missing, please contact an Öhlins dealer.

Warning!

Before you install this product, read the Öhlins Owner's manual. This product is an important part of the vehicle and the vehicle stability.

Front Fork for Yamaha YZF-R1, Yamaha YZF-R1M

FGRT 219

Mounting Instructions

MOUNTING INSTRUCTIONS

⚠ Warning!

We strongly recommend to let an authorized Öhlins dealer install this product.

⚠ Warning!

If you work with a lifted vehicle, make sure that it is safely supported to prevent it from tipping over.

👁 Note!

When you work with this product, see the vehicle service manual for vehicle specific procedures and important data.

👁 Note!

Before you install this product clean the vehicle.

1

Put the motorcycle on a work stand so that the front wheel barely touches the ground.

2

Remove the front fender, brake calipers, speed sensor and the front wheel. Refer to the vehicle service manual for correct procedure.

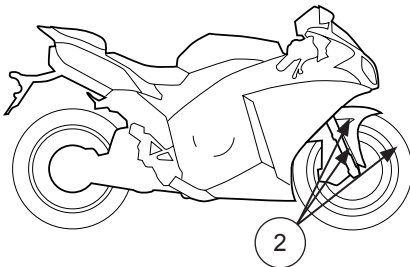

3

Measure the distance from the top of the outer fork leg to the top of the upper triple clamp. Note this distance.

👁 Note!

It is very important that the Öhlins front fork is installed at the exact same position as the OEM front fork.

4

Loosen the bolts to loosen the upper and the lower triple clamps.

5

Remove the fork legs from the motorcycle.

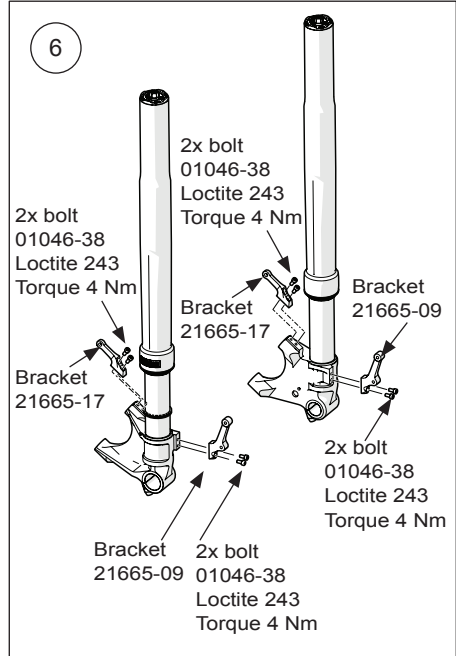
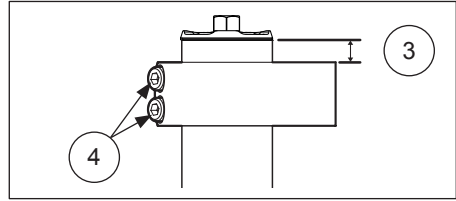

6

Apply Loctite 243 or similar to the bolts. Install the supplied fender brackets to the fork legs, see figure 6. Tighten the screws to 4 Nm.

7

Install the fork legs in the triple clamps at the same position as measured in step 3. Turn the handle bars fully from side to side to make sure that nothing restricts the movement, and that the throttle cable and the wire harness run in smooth bends.

👁 Note!

The eccentrically machined surfaces on the outer tube must be at a 90° angle from the vehicle direction.

MOUNTING INSTRUCTIONS

8

Tighten:

Upper triple clamp: 20 Nm

Lower triple clamp: 10 Nm

9

Install the front fender, front wheel and the brake calipers. Do not tighten yet.

11

⚠ Warning!

Ensure that the speed sensor cable does not touch the wheel at full lock turns and when the suspension is fully compressed or extended.

Install the speed sensor bracket. Cable routing according to the figure. Torque and thread locking according to vehicle service manual.

12

Put the vehicle on the ground, apply the front brake and compress the front fork distinctly 3-4 times. This will position the front fork legs parallel.

13

Tighten the front axle, brake calipers and the front fender.

Front axle pinch bolts torque: 19 Nm

14

Close the compression and rebound adjusters.

15

Compress the front fork as much as possible several times to bleed out the air. Ensure that there is damping on the full stroke.

16

Set the compression and rebound adjusters, see setup data on the next page.

👉 Caution!

Make sure that you tighten all screws to the correct torque and that nothing fouls or restricts movement of the front fork when the suspension is fully compressed or extended.

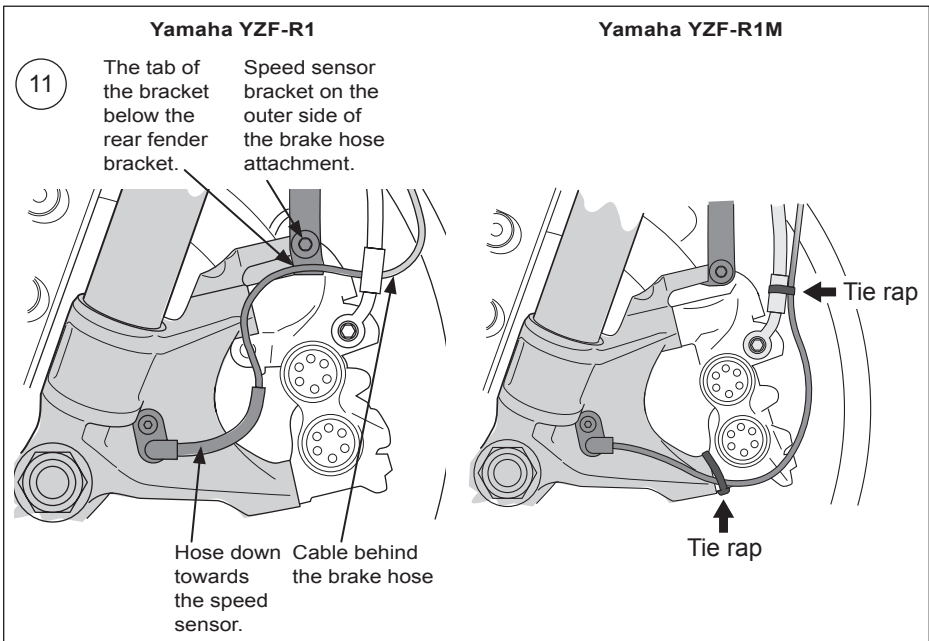

ADJUSTMENTS

⚠ Warning!

Before you ride/drive, always make sure that the setup is according to the recommended setup data. Read about adjustments and setting up in the Öhlins Owner's Manual before you make any adjustments. Contact an Öhlins dealer if you have any questions about set up.

Spring preload adjuster

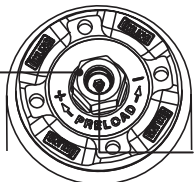

Compression/Rebound adjuster

SETUP DATA

Compression	12	clicks
Rebound	12	clicks
Spring preload	6	mm
Oil level	150	mm
Fork leg position	5	mm
Öhlins Front fork fluid	01309-01	

Spring

Part No.	Rate (N/mm)
04744-95 (optional)	9.5
04744-90 (optional)	9.0
04744-10 (standard)	10.0
04744-05 (optional)	10.5
04744-11 (optional)	11.0

OIL LEVEL - FORCE DIAGRAM

Air spring for one leg.

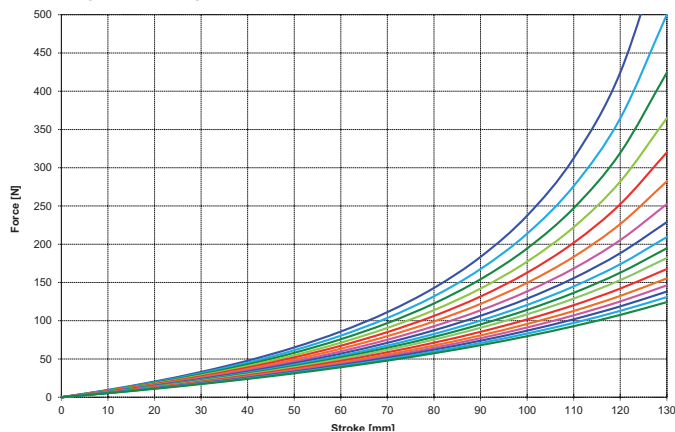

Oil level [mm]

- 140
- 150
- 160
- 170
- 180
- 190
- 200
- 210
- 220
- 230
- 240
- 250
- 260
- 270
- 280
- 290
- 300

Öhlins products are subject to continuous improvement and development, therefore, although these instructions include the most up-to-date information available at the time of printing, minor updates may occur.

To find the latest information contact an Öhlins distributor. Please contact Öhlins if you have any questions regarding the contents in this document.

Part no. MI_FGRT219_2
Issued 2017-07-07

© Öhlins Racing AB. All rights reserved. Any reprinting or unauthorized use without the written permission of Öhlins Racing AB is prohibited.

Öhlins Racing AB
Box 722
S-194 27 Upplands Väsby, Sweden
Phone +46 8 590 025 00
fax +46 8 590 025 80



www.ohlins.com