

⚠ Warning!

This kit should only be installed by an authorized Öhlins dealer. The installation procedure requires certain tools.

👁 Note!

Please note that there can be small differences between your product and the images in these instructions.

👁 Note!

Please note that during storage and transport, especially at high ambient temperature, some of the oil and grease used for assembly may leak and stain the packaging. This will not cause damage to the product, wipe off the excessive oil or grease with a cloth.

Kit Contents

Description	Part No	Pcs
Front fork kit	FKA 121	2
Shim 8/16/0.15	00185-16	1
Shim 8/18/0.10	00184-18	1
Shim 8/20/0.10	00184-20	1
Shim 8/24/0.10	00184-24	1
Shim 8/26/0.15	00185-26	1
Shim 8/11/0.30	00188-51	2
Spring 38.3/440/3.5	68042-35	2
Spring 38.3/440/4.5	68042-45	2
Washer 8/13/1 copper	60048-01	2
O-ring 34.2x3	00438-85	2
O-ring 44.2x3	00338-65	2
Adapter 25.6/41.9/10	21650-16	2
Screw K6S M8x20	05404-02	2
Owner's manual	07287-01	1
Sticker "TECHNOLOGY INSIDE" blue	00191-33	2
Sticker "TECHNOLOGY INSIDE" white	00191-32	2

👁 Note!

Before you install this product, check the kit contents. If anything is missing, please contact an Öhlins dealer.

⚠ Warning!

Before you install this product, read the Öhlins Owner's manual and this document. This product is an important part of the vehicle and the vehicle stability.

Front Fork Kit for Honda CRF300Rally / L

FKA 121

Mounting Instructions



MOUNTING INSTRUCTIONS

⚠ Warning!

We strongly recommend to let an Öhlins dealer install this product.

⚠ Warning!

If you work with a lifted vehicle, make sure that it is safely supported to prevent it from tipping over.

👁 Note!

When you work with this product, see the vehicle service manual for vehicle specific procedures and important data.

👁 Note!

Before you install this product clean the vehicle.

⚠ Warning!

Spring compression creates a potential danger because of the violent force that loaded springs are capable of. Beware of this when you work with the front fork.

TOOLS, GREASE AND FLUID

Tools needed for the original front fork

- Refer to the vehicle service manual for tools needed for removing/installing the front fork from the vehicle.
- Refer to the vehicle service manual for tools needed for removing the cartridge from the front fork.

Tools needed for the Öhlins cartridge kit

Tool	Part no	Applies	Size
Vehicle service manual			
Torque wrench			
Wrench		Shaft extension	19 mm
Hex key		Compression and rebound bleed adjusters	3 mm
Socket		Preload adjuster	14 mm
Ruler		Suspension fluid level	
Öhlins tool	01765-03	Shaft extension	
Wrench		Top cap	50 mm
Öhlins tool	01797-07	Seal head	
Soft jaw	00727-06	Cylinder tube	34 mm
Soft jaw	00727-02	Shaft	12 mm
Suspension fluid	01309-xx		
Grease	00146-01		100 g

MOUNTING INSTRUCTIONS

1 Remove the original front fork

👁 **Note!**

The following procedure applies to both front fork legs.

1.1

Put the motorcycle on a workstand so that the front wheel barely touches the ground.

⚠ **Warning!**

Make sure the vehicle is securely supported so that it will not fall over.

1.2

Remove front fender, brake calipers, speed sensor (if present) and front wheel.

1.3

Release main spring preload fully (if present).

1.4

Note front fork leg position.

1.5

Loosen upper triple clamp.

1.6

Loosen (do not remove) top cap ½ turn.

1.7

Loosen lower triple clamp.

1.8

Remove front fork legs from triple clamps.

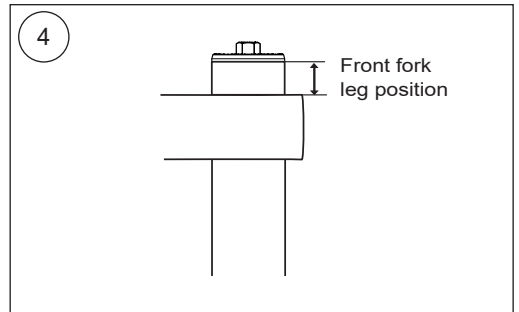

MOUNTING INSTRUCTIONS

2 Disassemble original front fork

2.1

Loosen top cap from outer tube.

2.2

Slide outer tube down until it stops.

2.3

Loosen and remove top cap from shaft according to vehicle service manual.

2.4

Remove main spring and associated parts according to instructions in the vehicle service manual.

2.5

Drain front fork leg of suspension fluid.

2.6

Loosen inner tube lock screw

Note!

If lock screw is not removed inner tube and fork bottom will be damaged.

Warning!

Inner tube thread may need to be repaired before removing inner tube [apply appropriate method].

2.7

Install inner tube tool on inner tube. Do not place tool at sealing or gliding surface.

[24670-01 Clamp tool]

[24669-02 Sleeve 43]

2.8

Soften thread locker between inner tube and fork bottom with a heat gun.

[Heat gun]

2.9

Remove inner tube from fork bottom.

2.10

Remove main spring preload adjuster and associated parts from fork bottom according to instructions in the vehicle service manual.

2.11

Remove cartridge and inner tube from left front fork leg.

2.12

Remove washer from inner tube right front fork.

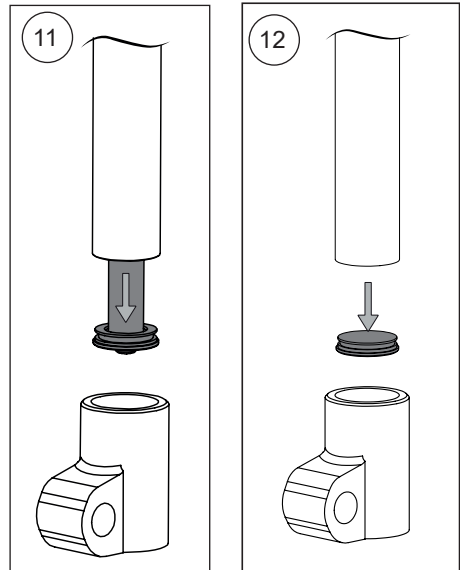

LEFT

RIGHT

3. Install the Öhlins cartridge kit

⚠ Caution!

The cartridge kit is divided into compression and rebound cartridges.

Install compression cartridge marked "COMP" in left hand side front fork leg.

Install rebound cartridge marked "REB" in right hand side front fork leg.

3.1

Remove top cap (A), spring support (B), guide sleeve and preload tube (C).

3.2

Insert adapter ring into the inner tube and fork bottom.

3.3

Insert cartridge into the front fork leg and clamp by inner tube.

3.4

Install bottom screw and washer according to instructions in the vehicle service manual.

3.5

Install inner tube using inner tube tool.

Apply Loctite 2700. Tighten to 120 Nm.

[24670-01 clamp tool]

[24669-02 sleeve 43 mm]

[01791-27 Loctite 2700]

👁 Note!

To get the correct torque, make sure to place the torque wrench in a 90 degree angle to the Fork tube tool.

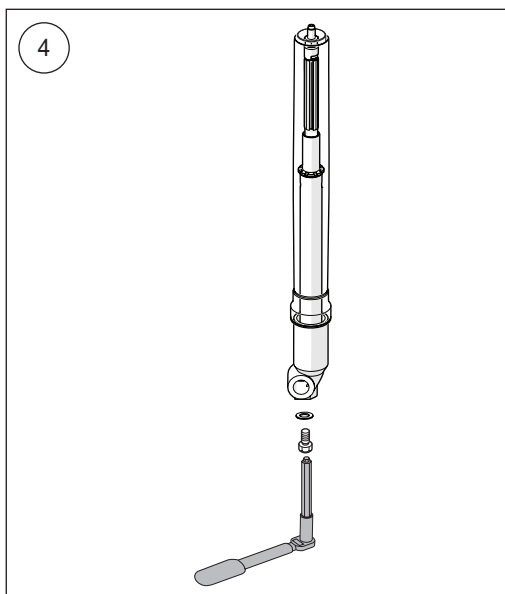
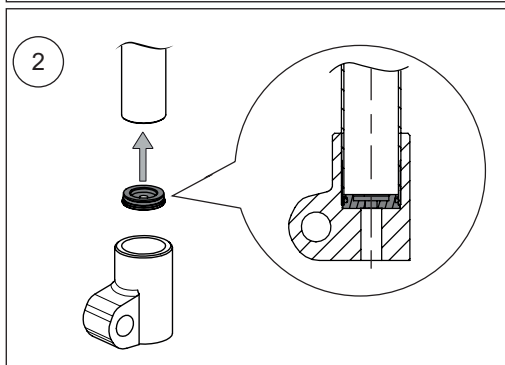
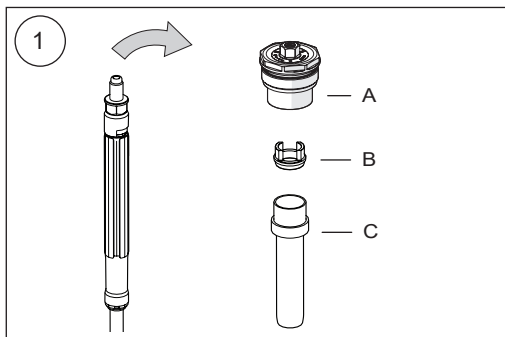
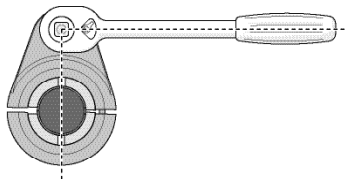

MOUNTING INSTRUCTIONS

3.6

Pour approximately 0.5 litre Öhlins suspension fluid in front fork leg.

⚠ Warning!

Fluid level must be approximately 50 mm above top of seal head.

3.7

Use a hex key to open compression and rebound adjusters fully. Install top cap directly to shaft extension (no main spring or preload tube). Pull up outer tube and tighten it to the top cap with your hand.

[Hex key 3 mm]

3.8

Pull outer tube up and down 10-15 times to pump out all air from the cartridge.

3.9

Remove top cap from front fork leg.

3.10

Make sure that shaft assembly and outer tube are in their bottom positions.

Set suspension fluid level according to chapter "Setup Data".

3.11

Install shaft extension tool on top of shaft extension.

Install main spring with the marking up (A), guide sleeve and preload tube (B) and spring support (C) over shaft extension tool.

[01765-03 shaft extension tool]

3.12

Pull up shaft assembly and grab spring support with a wrench tool.

[Wrench 19 mm]

3.13

Apply grease on o-ring and thread.

[00338-65 o-ring]

[00146-01 grease]

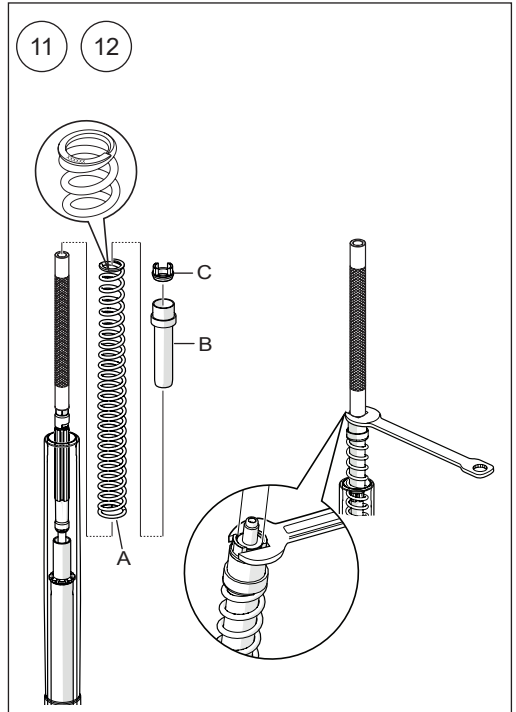
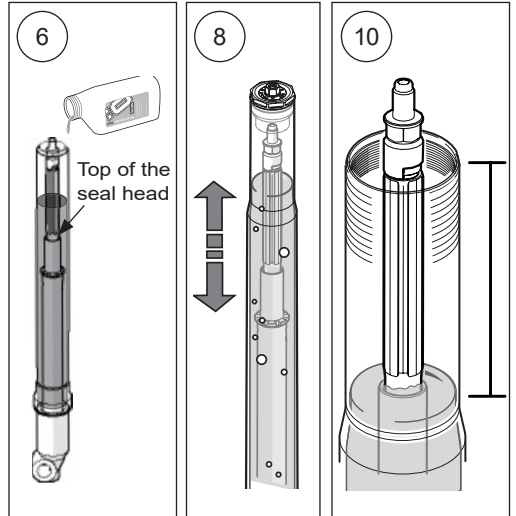

MOUNTING INSTRUCTIONS

3.14

Make sure that compression and rebound adjusters are fully open before installing top cap. Use a hex key to open compression and rebound adjusters. Remove pull-up tool and install top cap to the shaft extension. Tighten to 30 Nm.

[Hex key 3 mm]

[Socket 14 mm]

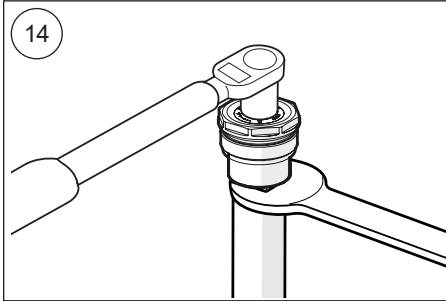

3.15

Remove wrench from spring support.

3.16

Pull up outer tube. Make sure front fork leg is in a fully extended position. Tighten top cap to outer tube. Tighten to 10 Nm.

[Wrench 50 mm]

3.17

Set compression, rebound and main spring adjusters according to chapter "Setup Data". Use a hex key for compression and rebound adjusters. Use a socket for main spring preload adjuster.

[Hex key 3 mm]

[Socket 14 mm]

4 Install the front fork in the vehicle

4.1

Install front fork legs in vehicle at recommended front fork leg position, according to chapter "Setup data".

4.2

Remaining installation, instructions according to vehicle service manual.

5. Compression shims upgrade

(for road use)

5.1

Remove the compression cartridge kit by remove the top cap and spring

5.2

Remove the seal head and cylinder tube.

[00727-06 soft jaws 34 mm]

[01797-07 Öhlins tools]

5.3

Clamp the shaft and remove the nut

[00727-02 soft jaws 12 mm]

5.4

Replace the shims Shim 8/11/0.15 (4pcs) according to chapter "Shims setting".

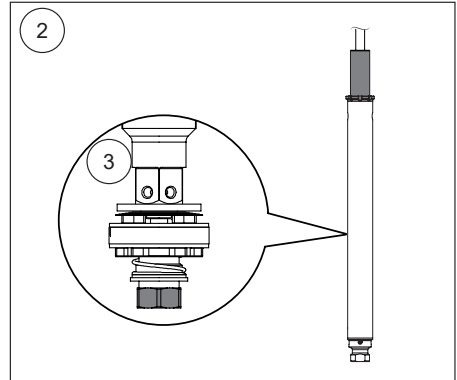

5.5

Install nut on the shaft. Tighten torque 7 Nm.

[01791-25 loctite 2400]

5.6

Install seal head on cylinder tube. Tighten torque 60 Nm.

[69024-01 loctite 603]

5.7

Reverse all the procedures as necessary.

SETUP DATA

Compression	12	clicks
Rebound	12	clicks
Suspension fluid level	140	mm
Suspension fluid volume	420	ml
Front leg position	Standard position	
Suspension fluid	01309-xx	

MAIN SPRING RECOMMENDATION

Make sure you choose the correct main spring for your rider weight, driving style and preferences. Below you find a general recommendation of main spring rate for your weight. Contact an authorized Öhlins service center for advice.

Rider weight [kg]	Less than 80		80		More than 80	
Spring rate [N/mm]	3.5		4.0		4.5	
Preload [turns]	1		0		0	
Part number (L/R)	68042-35	68042-35	68042-35	68042-45	68042-45	68042-45

Spring are packed in pairs.

SHIMS SETTING

Item	Part no.	Description	Quantity	Note
1	00185-26	Shim 8/26/0.15	1	setting optional alternative for dual sport performance.
2	00184-24	Shim 8/24/0.10	1	
3	00184-20	Shim 8/20/0.10	1	
4	00184-18	Shim 8/18/0.10	1	
5	00185-16	Shim 8/16/0.15	1	
6	00188-51	Shim 8/11/0.30	2	

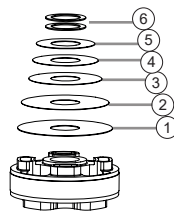

Öhlins products are subject to continuous improvement and development, therefore, although these instructions include the most up-to-date information available at the time of printing, minor updates may occur.

To find the latest information contact an Öhlins distributor. Please contact Öhlins if you have any questions regarding the contents in this document.

Part no. MI_FKA121_0
Issued 2024-03-29

© Öhlins Racing AB. All rights reserved. Any reprinting or unauthorized use without the written permission of Öhlins Racing AB is prohibited.

Öhlins Asia Co. Ltd
700/937 Moo5, Tambol Nongkhaga,
Amphur Phantong, Chonburi Province
20160 Thailand



www.ohlins.com