

ADJUSTMENTS

⚠ Warning!

Before riding, always make sure that the basic settings made by Öhlins are according to recommended Set-up Data. Read about adjustments and setting up in the Öhlins Owner's Manual before you make any adjustments. Contact an Öhlins dealer if you have any questions about setting up the shock absorber.

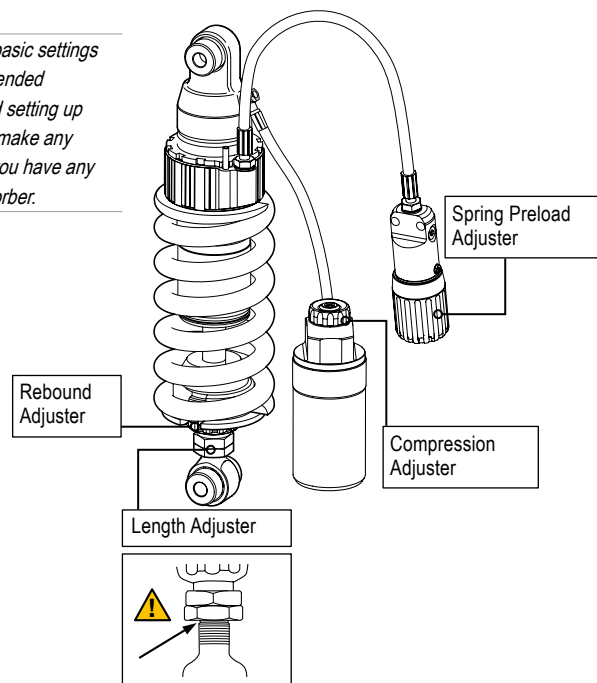

SET-UP DATA

Recommended set-up

Spring Preload	13 mm
Compression Damping	14 clicks
Rebound Damping	16 clicks

Shock Absorber Data

Length	321,5 ⁺⁶ / ₀ mm
Stroke	50,5 mm

Before installing this product, check the contents of the kit. If anything is missing, please contact an Öhlins dealer.

Kit Contents

	Part No.	Pcs.
Shock Absorber	HO105	1
Sticker Öhlins blue/transp	00191-06	1
Sticker Öhlins Yellow/blue	00192-01	1
Nut M6	00430-02	2
Nut M5	00430-04	3
Screw M6x30	01046-02	2
Screw M5x16	01046-18	2
Screw M5x22	01046-26	1
Sticker Memo Notes	01180-01	1
Reservoir bracket	05378-10	1
Bracket	21617-12	1
Washer	21617-13	1
Tie-wrap	00231-01	1
Öhlins Owner's Manual	07241-02	1

Please note that during storage and transportation, especially at high ambient temperature, some of the oil and grease used for assembling may leak and stain the packaging. This is in no way detrimental to the product, wipe off the excessive oil/grease with a cloth.

⚠ Warning!

Before installing this product, read the Öhlins Owner's Manual. The shock absorber is an important part of your vehicle and will affect the stability.

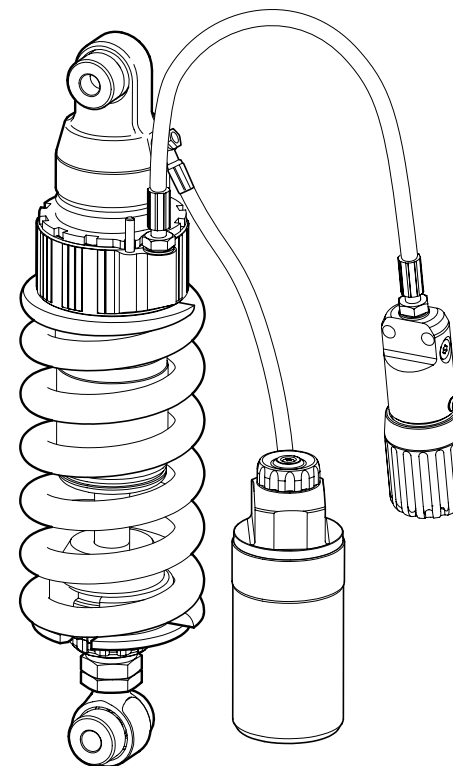

Öhlins products are subject to continuous improvement and development, therefore, although these instructions include the most up-to-date information available at the time of printing, minor updates may occur.

To find the latest information contact your Öhlins distributor. Please consult your Öhlins dealer if you have any questions regarding the contents in this document.

Part no. HO105_0
Issued 2011-08-30



Shock Absorber for Honda VFR 800X Crossrunner

HO 105

Mounting Instructions

© Öhlins Racing AB. All rights reserved. Any reprinting or unauthorized use without the written permission of Öhlins Racing AB is prohibited.

Öhlins Racing AB
Box 722
S-194 27 Upplands Väsby, Sweden
Phone +46 8 590 025 00
fax +46 8 590 025 80



www.ohlins.com



⚠ Warning!

It is advisable to have an Öhlins dealer install the shock absorber.

⚠ Warning!

When installing, consult your Vehicle Service Manual.

⚠ Warning!

When working on a raised vehicle ensure that the vehicle is securely supported so that it will not tip.

👁 Note!

Before installing the Öhlins shock absorber clean the vehicle thoroughly.

1

Put the motorcycle on a workstand so that the rear wheel barely touches the ground.

2

Remove seat, side fairings and left side passenger foot peg.

3

Loosen the fuel tank and lift the rear end of the fuel tank slightly so that the upper bolt nut of the original shock absorber is visible.

4

Loosen the upper bolt nut of the original shock absorber.

5

Loosen the lower bolt, pull rod and triangle link. Remove the pull rod and triangle link from the frame.

👁 Note!

Note how the pull rod and triangle link were mounted.

6

Remove the original shock absorber.

7

Remove the bracket from the original shock absorber and mount it on the Öhlins shock absorber. Remove the end eye from the Öhlins shock absorber.

8

Mount the Öhlins shock absorber. The hydraulic preload adjuster and the reservoir shall be pulled out from the left side of the vehicle.

👁 Note!

Lower the motorcycle so that the shock absorber is slightly compressed, before tightening the screws.

9

Remount the end eye. Tighten.

10

Mount the lower shock absorber bolt.

11

Mount the pull rod and triangle link.

👁 Note!

Make sure to remount the pull rod and triangle link in the same way as they were before.

12

Mount the hydraulic preload adjuster to the left rear foot peg bracket. Use the bracket, washer, screws and nuts provided.

13

Fasten the hoses with the tie-wrap provided.

14

Mount the fuel tank, side fairings and seat.

👉 Caution!

Make sure that all screws are tightened to the correct torque and that nothing fouls or restricts movement of the shock absorber when the suspension is fully compressed or extended.

