

Before installing this product, check the contents of the kit. If anything is missing, please contact your nearest Öhlins dealer.

Kit Contents

	Part No.	Pcs.
Steering damper stroke 68	02262-20	1
Bracket assy	02230-12	1
Bolt M6x30	01046-02	1
Bolt M6x25	01046-17	1
Sleeve 6x15	02239-01	1
Sleeve 6x18.5	02239-02	1
Sticker Öhlins	00192-01	2
Owner's Manual	07261-02	1

Please note that during storage and transportation, especially at high ambient temperature, some of the oil and grease used for assembling may leak and stain the packaging. This is in no way detrimental to the product, wipe off the excessive oil/grease with a cloth.

▲ Warning!

Before installing this product, read the Öhlins Owner's Manual. The shock absorber is an important part of your vehicle and will affect the stability.

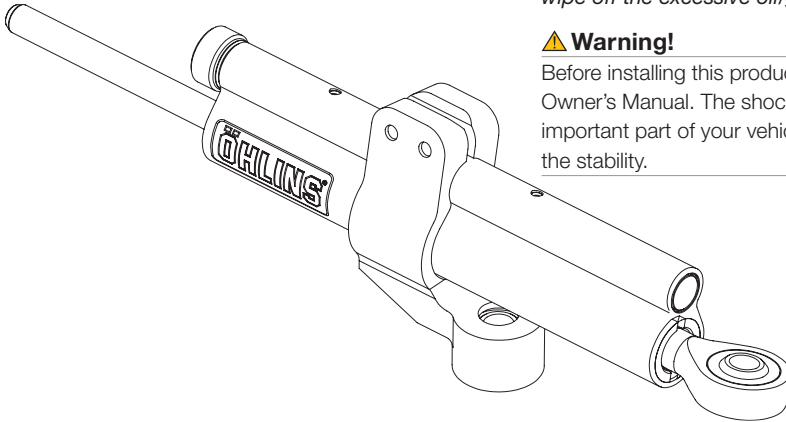

Steering Damper for Ducati

SD 031

Mounting Instructions



How to install

⚠ Warning!

It is advisable to have an Öhlins dealer install the steering damper.

When installing, read your Vehicle Service Manual.



1

Put the motorcycle on a workstand so that the rear wheel barely touches the ground. Loosen and remove the original steering damper.

⚠ Warning!

Make sure the vehicle is securely supported so that it will not tip.

2

Install the bracket assembly (02230-12) to the upper triple clamp. Use the short bolt (01046-17) and shorter sleeve (02239-01).

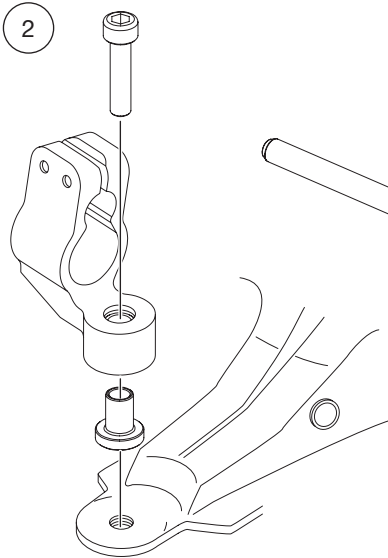

3

Install the Öhlins steering damper to the bracket assembly. Install the end eye to the frame bracket on the right side. Use the bolt (01046-02) and the longer sleeve (02239-02).

👉 Caution!

Make sure there is clearance when turning the steering to the left and right end positions and that the damper is not used as a stop.

4

Tighten the bolts to correct torque.

5

Set the damper to the recommended set-up in this folder.

👉 Caution!

Make sure that all screws are tightened to the correct torque and that nothing fouls or restricts movement of the steering damper.

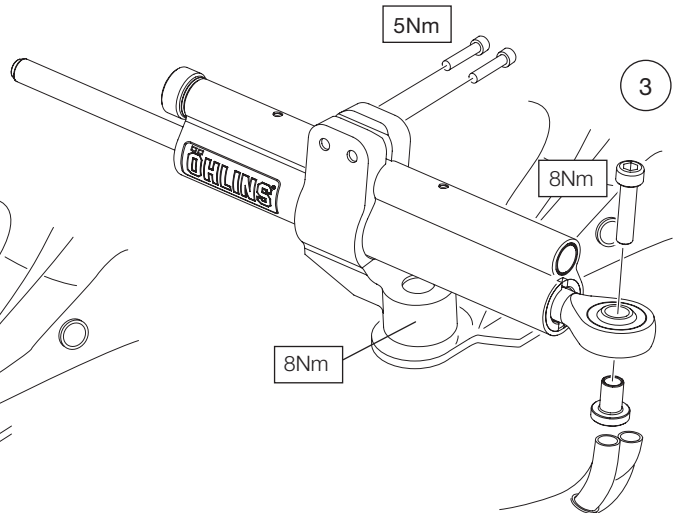

⚠ Warning!

Before riding, always make sure that the basic settings made by Öhlins are according to recommended Set-up Data. Read about adjustments and setting up in the Öhlins Owner's Manual before you make any adjustments. Contact an Öhlins dealer if you have any questions about setting up the shock absorber.

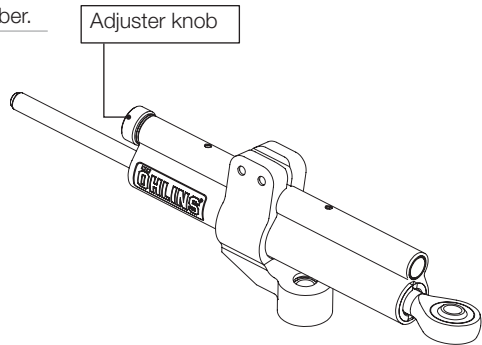

Set-up Data

Recommended set-up

10 clicks

👁️ Öhlins products are subject to continuous improvement and development, therefore, although these instructions include the most up-to-date information available at the time of printing, minor updates may occur.

To find the latest information contact your Öhlins distributor. Please consult your Öhlins dealer if you have any questions regarding the contents in this document.

Part no. SD031_2
Issued 2016-03-14

© Öhlins Racing AB. All rights reserved. Any reprinting or unauthorized use without the written permission of Öhlins Racing AB is prohibited.

Öhlins Racing AB
Box 722
S-194 27 Upplands Väsby, Sweden
Phone +46 8 590 025 00
fax +46 8 590 025 80



www.ohlins.com