

**Note!**

Please note that this image is a general representation of the product and may differ slightly from your product.

**Note!**

Please note that during storage and transportation, especially at high ambient temperature, some of the oil and grease used for assembling may leak and stain the packaging. This is in no way detrimental to the product, wipe off the excessive oil/grease with a cloth.

**Note!**

Before installing this product, check the contents of the kit. If anything is missing, please check an Öhlins dealer.

**Kit Contents**

Description	Part No	Pcs
Shock absorber	TR 134	1
C-spanner S46	60710-02	1
Sticker set "ÖHLINS"	10207-01	1
Owners manual	07241-02	1

**Warning!**

Before installing this product, read the Öhlins Owner's Manual. The shock absorber is an important part of your vehicle and will affect the stability.

## Shock Absorber for Triumph Trident 660

# TR 134

## Mounting Instructions



# MOUNTING INSTRUCTIONS

## **⚠ Warning!**

*It is advisable to have an Öhlins dealer install the shock absorber.*

## **⚠ Warning!**

*If working on a raised vehicle, ensure it is securely supported so that it will not tip over.*

## **👁 Note!**

*Before mounting this product clean the vehicle thoroughly.*

## **👁 Note!**

*When working on this product, always see the Vehicle Service Manual for vehicle specific procedures and important data.*

1. Put the motorcycle on a work stand so that the rear wheel barely touches the ground. Make sure the motorcycle is in a stable position.

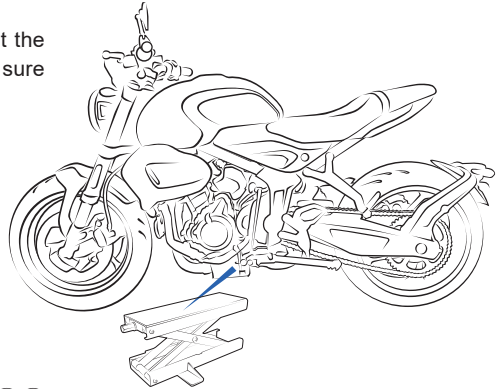

2. Loosen the screws ① on left side and ②③ on right side, then unlocking the push clips ④⑤ under mudguard cover in order to remove the chainguard and mudguard ①A.

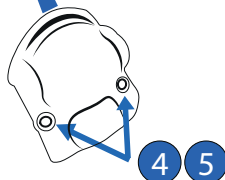
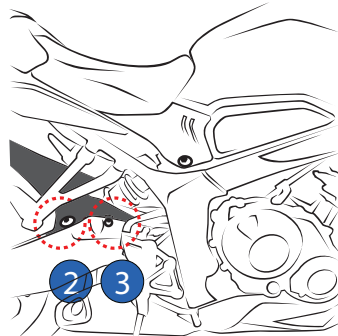
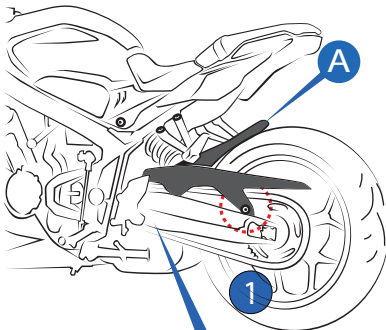

# MOUNTING INSTRUCTIONS

3.

Remove the seat **(B)** by using the key unlock.

3.1

Loosen the screw **(1)(2)** by disconnect negative (-) cable first and then disconnect the positive (+) battery cable in order to remove the battery from box.

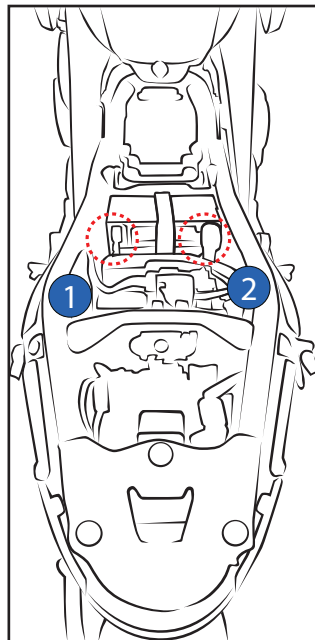
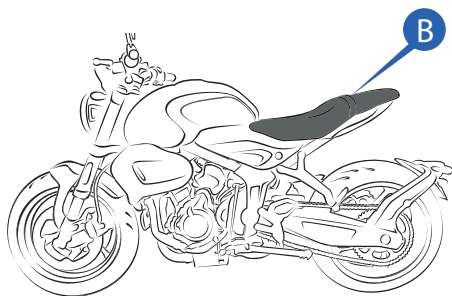

3.2

Loosen the screw **(3)(4)** in order to remove the cover **(C)** on both sides from the motorcycle

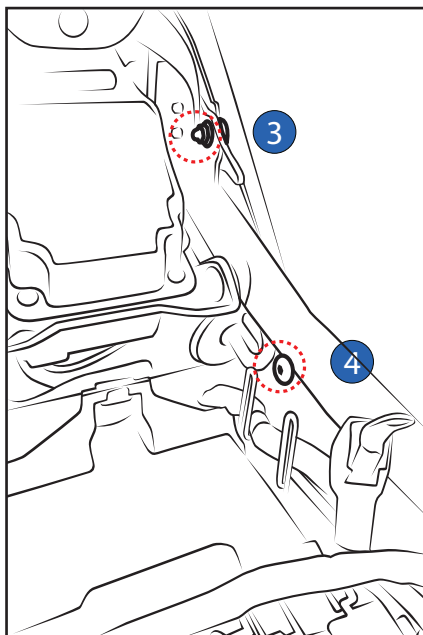
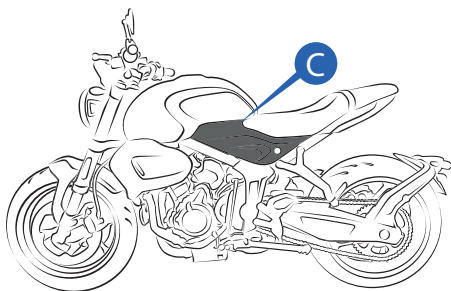

# MOUNTING INSTRUCTIONS

4.

Remove the standard shock absorber by loosening the top mounting ① and the lower mounting bolts ②

4.1

Install the Öhlins shock absorber ④ with the hose pointing towards the front of the motorcycle and tighten the upper ① and the lower mounting bolts ② at a torque value as specified in the vehicle service manual.

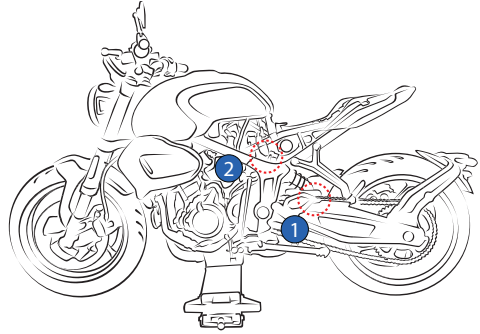

5.

Reverse all the procedure as necessary.

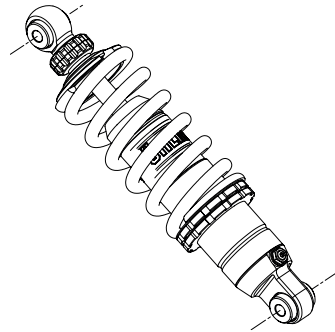
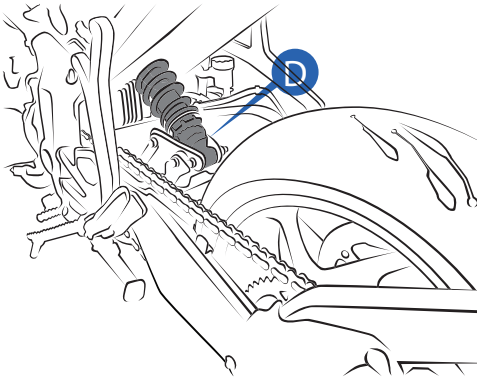

## 👁️ **Note!**

Avoid interference between preload lock nut and lower mounting swing arm on motorcycle when the suspension is a fully extended. Make sure the minimum position is 74.5 mm distance as in the picture shown. (Incase customer reduce preload ).

## 👁️ **Note!**

Lower the vehicle so that the suspension is slightly compressed before tightening the screws.

## 👋 **Caution!**

Ensure that all screws are tightened to the correct torque and that nothing fouls or restricts movement

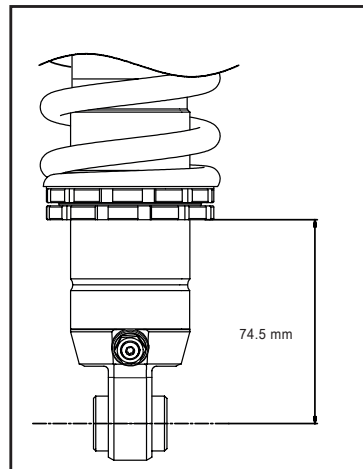

This page intentionally left blank

This page intentionally left blank

This page intentionally left blank

# ADJUSTMENTS

## **⚠ Warning!**

*Before riding, always make sure that the basic settings made by Öhlins are according to recommended Set-up Data. Read about adjustments and setting up in the Öhlins Owner's Manual before you make any adjustments. Contact an Öhlins dealer if you have any questions about setting up.*

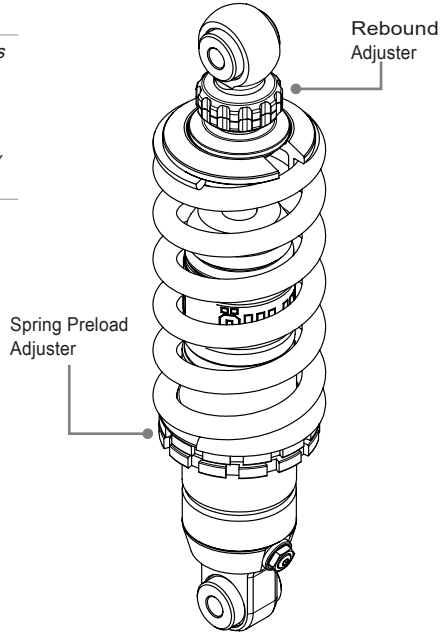

# SET-UP DATA

## **Recommended set-up**

Spring Preload..... 12 mm.  
Rebound adjuster ..... 12 Clicks

## **Shock absorber data**

Length ..... 305 mm.  
Stroke ..... 58 mm.

## **Spring Installed spring**

Part No ..... 61091-24  
Free spring length... 160 mm.  
Spring rate..... 80 N/mm  
Preload adj.range.... [0-24] mm.

👁 Öhlins products are subject to continuous improvement and development, therefore, although these instructions include the most up-to-date information available at the time of printing, minor updates may occur.

To find the latest information contact an Öhlins distributor. Please contact Öhlins if you have any questions regarding the contents in this document.

Part no. MI\_TR 134\_EN\_0  
Issued 2021-12-08

© Öhlins Asia Co. Ltd. All rights reserved. Any reprinting or unauthorized use without the written permission of Öhlins Racing AB is prohibited.

Öhlins Asia Co. Ltd  
700/937 Moo5, Tambol Nongkhaga,  
Amphur Phantong, Chonburi Province  
20160 Thailand



[www.ohlins.com](http://www.ohlins.com)