

Before installing this product, check the contents of the kit. If anything is missing, please contact an Öhlins dealer.

#### Kit Contents

	Part No.	Pcs.
Shock absorber	YA013	1
Washer	00153-01	2
Sticker set Öhlins		1
Tie-rop	00231-01	2
Nut M5	00430-04	3
Nut M8	00430-05	2
Screw 5x16	01046-18	2
Screw 8x40	01046-21	2
Screw 5x22	01046-26	1
Memo Notes Sticker	01180-01	1
Reservoir bracket carbon	05378-10	1
Owner's Manual	07241-02	1
Bracket	21617-09	1

Please note that during storage and transportation, especially at high ambient temperature, some of the oil and grease used for assembling may leak and stain the packaging. This is in no way detrimental to the product, wipe off the excessive oil/grease with a cloth.

#### **⚠ Warning!**

Before installing this product, read the Öhlins Owner's Manual. The shock absorber is an important part of your vehicle and will affect the stability.

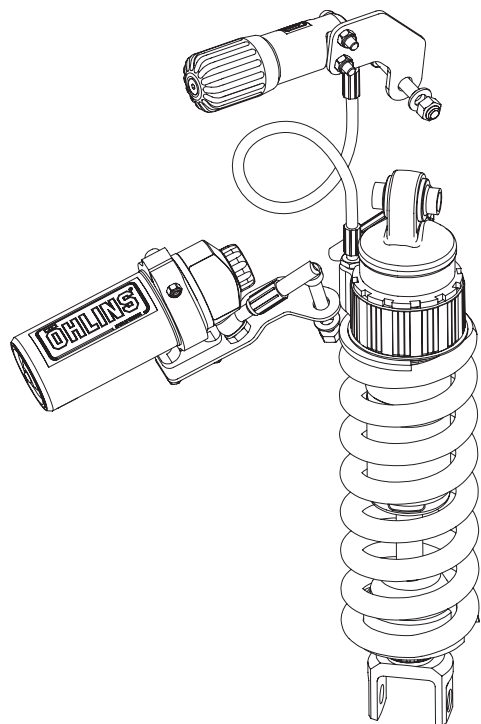

## Shock Absorber for Yamaha XT1200Z Super Ténéré **YA 013**

### Mounting Instructions



# How to install

## **⚠ Warning!**

It is advisable to have an Öhlins dealer install the shock absorber.

When installing, consult your Vehicle Service Manual.

**1**

Put the motorcycle on the centre stand.

## **⚠ Warning!**

Make sure the vehicle is securely supported so that it will not tip.

**2**

Loosen the cable / brake hose guide from the rear sub frame. (On the right side of the bike)

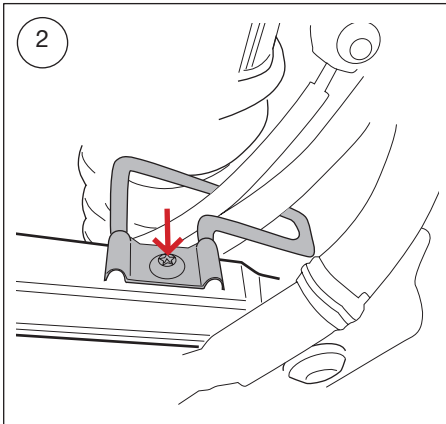

**3**

Loosen the linkage pull rods from the swing arm.

**4**

Remove the lower shock absorber mounting bolt.

**5**

Raise the rear wheel about 50 mm with a piece of wood or what you have available while removing the shock absorber..

**6**

Remove the upper shock mounting bolt and remove the standard shock by lowering it and taking it out on the right side of the bike.

## **👁 Note!**

Before installing the Öhlins shock absorber clean the vehicle thoroughly.

**7**

Install the Öhlins shock absorber with the hose connections to the right side of the bike using the standard mounting bolts. Reinstall the suspension linkage pull rods to the swing arm.

**8**

Fit the brackets for the reservoir and pre-load adjuster to the rear frame according to the figures. Exchange the standard bolts for the passenger foot peg to the supplied M8x40mm bolts. Use the 8mm washers and M8 nuts to fix the brackets on the inside of the frame.

**9**

Install the reservoir with the enclosed M5 screws and plastic bracket.

**10**

Tie up the hose with the tie-wraps.

## **👁 Note!**

Lower the motorcycle so that the shock absorber is slightly compressed, before tightening the screws.

**11**

Check that all screws and parts removed are re-installed and tightened.

## **👁 Caution!**

Ensure that the hydraulic preload adjuster hose runs in soft bends. Also check that it does not come in contact with the exhaust pipe or any sharp edges.

## **👁 Caution!**

Make sure that all screws are tightened to the correct torque and that nothing fouls or restricts movement of the shock absorber when the suspension is fully compressed or extended.

View from the right side of the vehicle.

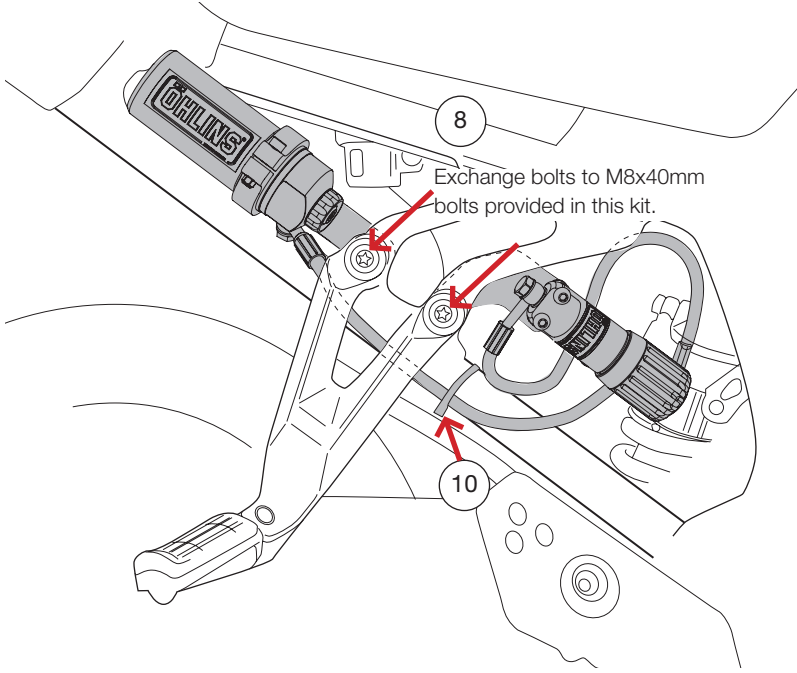

# Adjustments

## ⚠ Warning!

Before riding, always make sure that the basic settings made by Öhlins are according to recommended Set-up Data. Read about adjustments and setting up in the Öhlins Owner's Manual before you make any adjustments. Contact an Öhlins dealer if you have any questions about setting up the shock absorber.

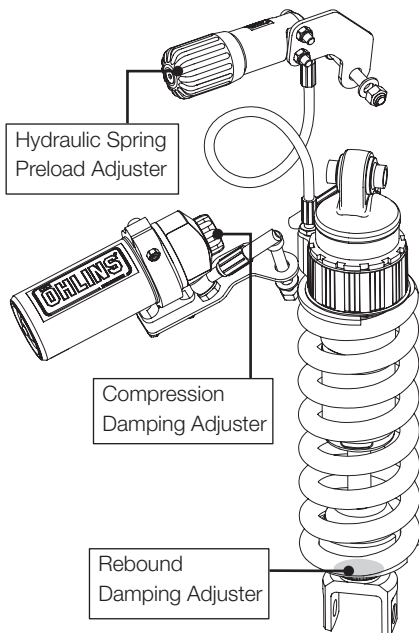

## Set-up Data

### Recommended set-up

Rebound	16 clicks
Compression	10 clicks
Spring Preload	12 mm
<b>Spring</b>	
Part No.	01099-49
Rate	130 N/mm
Spring, free length	220 mm

### Shock absorber data

Length	352,5 mm
Stroke	73,5 mm

### Free Sag and Ride Height

R1 - R2 =	42 mm
R1 - R3 =	73 mm

👁 Öhlins products are subject to continuous improvement and development, therefore, although these instructions include the most up-to-date information available at the time of printing, minor updates may occur.

To find the latest information contact your Öhlins distributor. Please consult your Öhlins dealer if you have any questions regarding the contents in this document.

Part no. YA013\_1  
Issued 2017-01-01



© Öhlins Racing AB. All rights reserved. Any reprinting or unauthorized use without the written permission of Öhlins Racing AB is prohibited.

Öhlins Racing AB  
Box 722  
S-194 27 Upplands Väsby, Sweden  
Phone +46 8 590 025 00  
fax +46 8 590 025 80



[www.ohlins.com](http://www.ohlins.com)