

Kit Contents

Description	Part No	Pcs
Shock absorber	YA 468	1
Sticker memo notes	01180-01	1
Sticker set Öhlins		1
Owner's manual	07242-07	1

👁 Note!

Please note that there can be small differences between your product and the images in these instructions.

👁 Note!

Please note that during storage and transport, especially at high ambient temperature, some of the oil and grease used for assembly may leak and stain the packaging. This will not cause damage to the product, wipe off the excessive oil or grease with a cloth.

👁 Note!

Before you install this product, check the kit contents. If anything is missing, please contact an Öhlins dealer.

⚠ Warning!

Before you install this product, read the Öhlins Owner's manual. This product is an important part of the vehicle and the vehicle stability.

Shock absorber for Yamaha R1/(R1M)

YA 468

Mounting Instructions



MOUNTING INSTRUCTIONS

⚠ Warning!

We strongly recommend to let an Öhlins dealer install this product.

⚠ Warning!

If you work with a lifted vehicle, make sure that it is safely supported to prevent it from tipping over.

👁 Note!

When you work with this product, see the vehicle service manual for vehicle specific procedures and important data.

👁 Note!

Before you install this product clean the vehicle.

1

Put the bike on a stand so that the rear wheel is off the ground.

2

Remove the rear shock linkage bolt.

3

Remove the lower shock mounting bolt.

4

Remove the front shock linkage frame bolt and bearing sleeve at the frame so the linkage is removable.

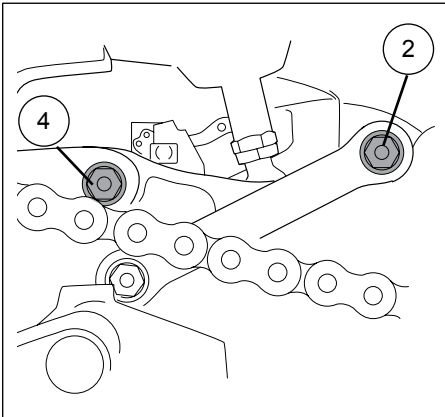

5

Remove the upper shock mounting bolt.

6

Remove the shock absorber to the left.

👁 Note!

Adjust the swing arm height with a stand or similar to make the removal easier.

7

Put the Öhlins shock and linkage in place.

8

Install the shock absorber mounting bolt and the linkage. Load the suspension slightly before tightening.

9

Make sure that all bolts are tightened and that there are no clearance problems when the rear wheel is moving.

👁 Note!

The Öhlins shock absorber will also fit the R1M model. Note that when you disconnect the STD shock absorber an error message will be shown on the display and you will not be able to enter the main menu.

10

Set system to non-electronic suspension.

Turn ignition off.

Hold gray arrow up button + mode button.

Turn ignition on and wait for display to show menu set up mode.

Release gray arrow up button + mode button.

Select "meter" with gray arrow up/down button.

Press gray arrow up button + mode button to go to next menu.

Select 2 for Öhlins electronic suspension, and 1 for non-electronic suspension.

Turn ignition off.

MOUNTING INSTRUCTIONS

ADJUSTMENTS

⚠ Warning!

Before you ride/drive, always make sure that the setup is according to the recommended setup data. Read about adjustments and setting up in the Öhlins Owner's Manual before you make any adjustments. Contact an Öhlins dealer if you have any questions about setting up.

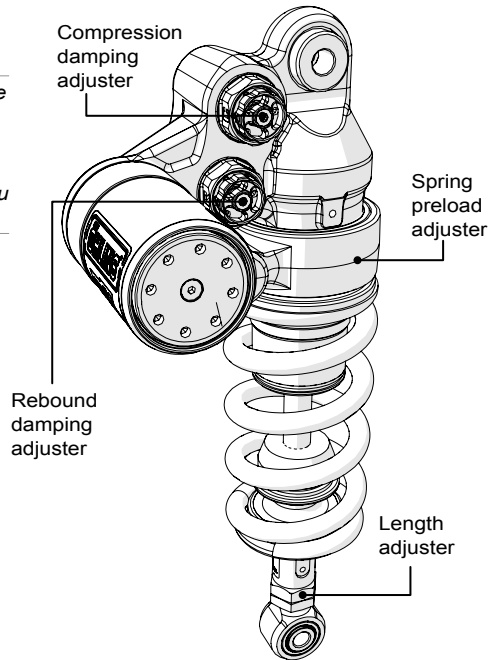

SETUP DATA

Length	315+6/0	mm
Stroke	58	mm
Rebound	16	clicks
Compression	13	clicks
Spring (part no.)	21041-29	
Spring preload	14	mm
Spring rate	90	N/mm
Spring free length	150	mm

Recommended free sag and ride height		
R1-R3	32	mm
F1-F3	43	mm

Öhlins products are subject to continuous improvement and development, therefore, although these instructions include the most up-to-date information available at the time of printing, minor updates may occur.

To find the latest information contact an Öhlins distributor. Please contact Öhlins if you have any questions regarding the contents in this document.

Part no. MI_YA468_0
Issued 2017-10-30

© Öhlins Racing AB. All rights reserved. Any reprinting or unauthorized use without the written permission of Öhlins Racing AB is prohibited.

Öhlins Racing AB
Box 722
S-194 27 Upplands Väsby, Sweden
Phone +46 8 590 025 00
fax +46 8 590 025 80



www.ohlins.com